

# SolarTerrace II-A

Code-Compliant Planning and Installation V 4.2  
Complying with AS/NZS 1170.2:2021

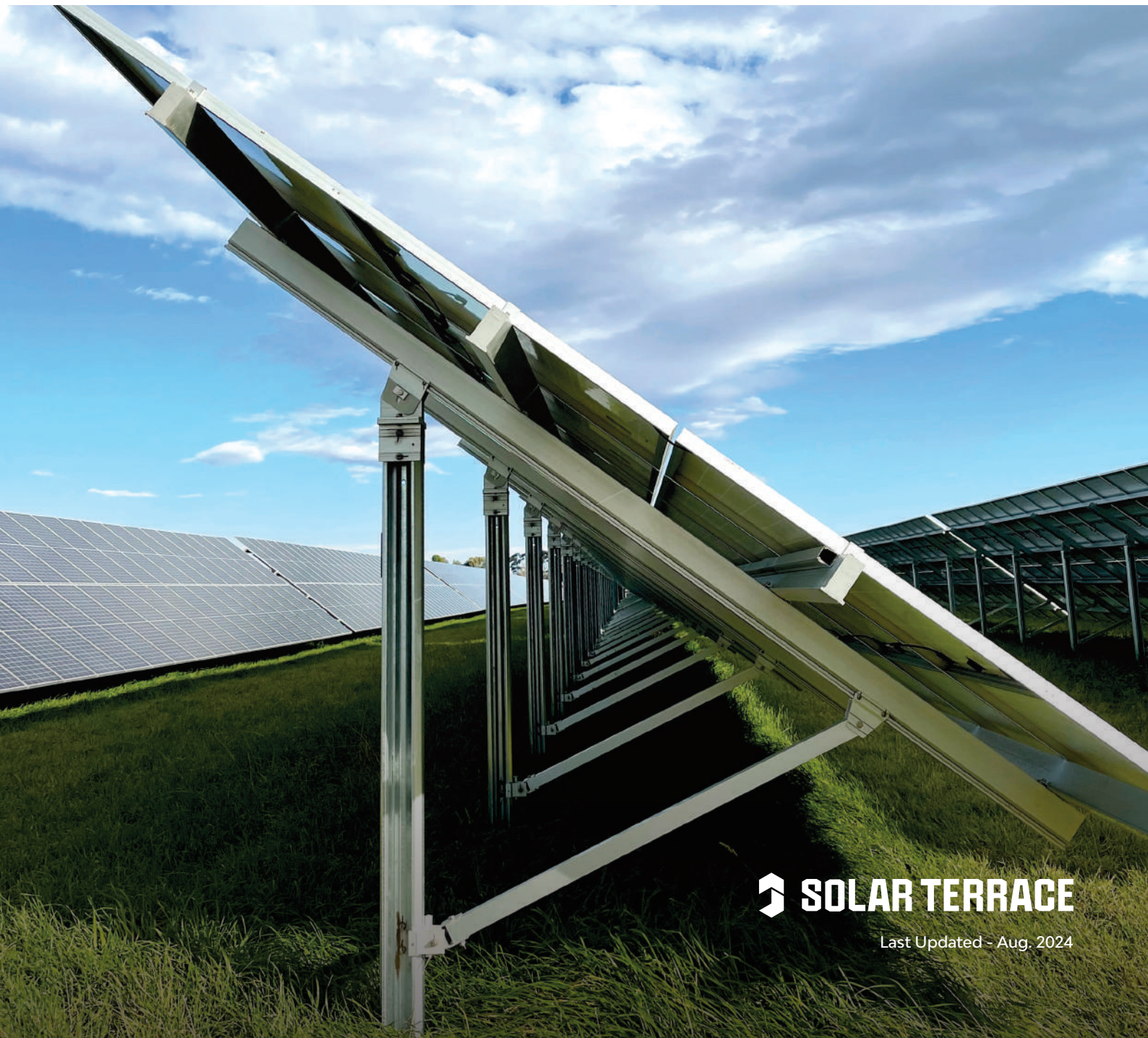

# Introduction

Clenergy PVezRack® SolarTerrace II-A is a pre-assembled ground mount system suitable for large scale commercial and utility scale installations. PVezRack® SolarTerrace II-A has been developed to fit any PV module. The innovative and patented SolarTerrace II-A T-Rails simplify and improve the accuracy of the installation. SolarTerrace II-A uses high quality engineered components, saving developers and installers' time and money when delivering ground mount projects.

Please review this instruction guide thoroughly before installing PVezRack® SolarTerrace II-A. This manual provides the supporting documentation for building permit applications relating to PVezRack® SolarTerrace II-A Universal PV Mounting System.

## List of contents

Introduction	01
Planning	02
Tools & Components	04
System Overview	06
Installation Instruction	08
AU Certification	28
NZ Certification	43

The PVezRack® SolarTerrace II-A components, when installed in accordance with this guide, will be structurally adequate and will meet the AS/NZS 1170.2:2021 standard. During installation and especially when working on the ground, you will need to comply with the appropriate occupational health and safety regulations. Please also check other regulations relevant to your local region. Make sure that you are using the latest version of the installation instruction guide, which you can do by contacting Clenergy by email on [tech@clenergy.com.au](mailto:tech@clenergy.com.au) or contacting your local distributor.

### Product Warranty:

Please refer [PVezRack® Product Warranty](#) on our website.

### The installer is solely responsible for:

- Complying with all applicable local or national building codes, including any that may supersede this manual;
- Ensuring that PVezRack® and other products are appropriate for the particular installation and the installation environment;
- Using only PVezRack® parts and installer-supplied parts as specified by ezRack (substitution of parts may void the warranty and invalidate the letter of certification);
- Ensuring that the ground condition are suitable;
- How to recycle: according to the local relative statute;
- How to disassemble: reverse installation process;
- Ensure that there are no less than two professionals working on the panel installation;
- Ensure the installation of the electrical equipment is performed by a professional and accredited electrician;
- Ensuring safe installation of all electrical aspects of the PV array including providing adequate earth bonding of the PV array and PVezRack® SolarTerraceII-A components as required in AS/NZS 5033: 2021.

# Planning

Determine the wind region of your installation site

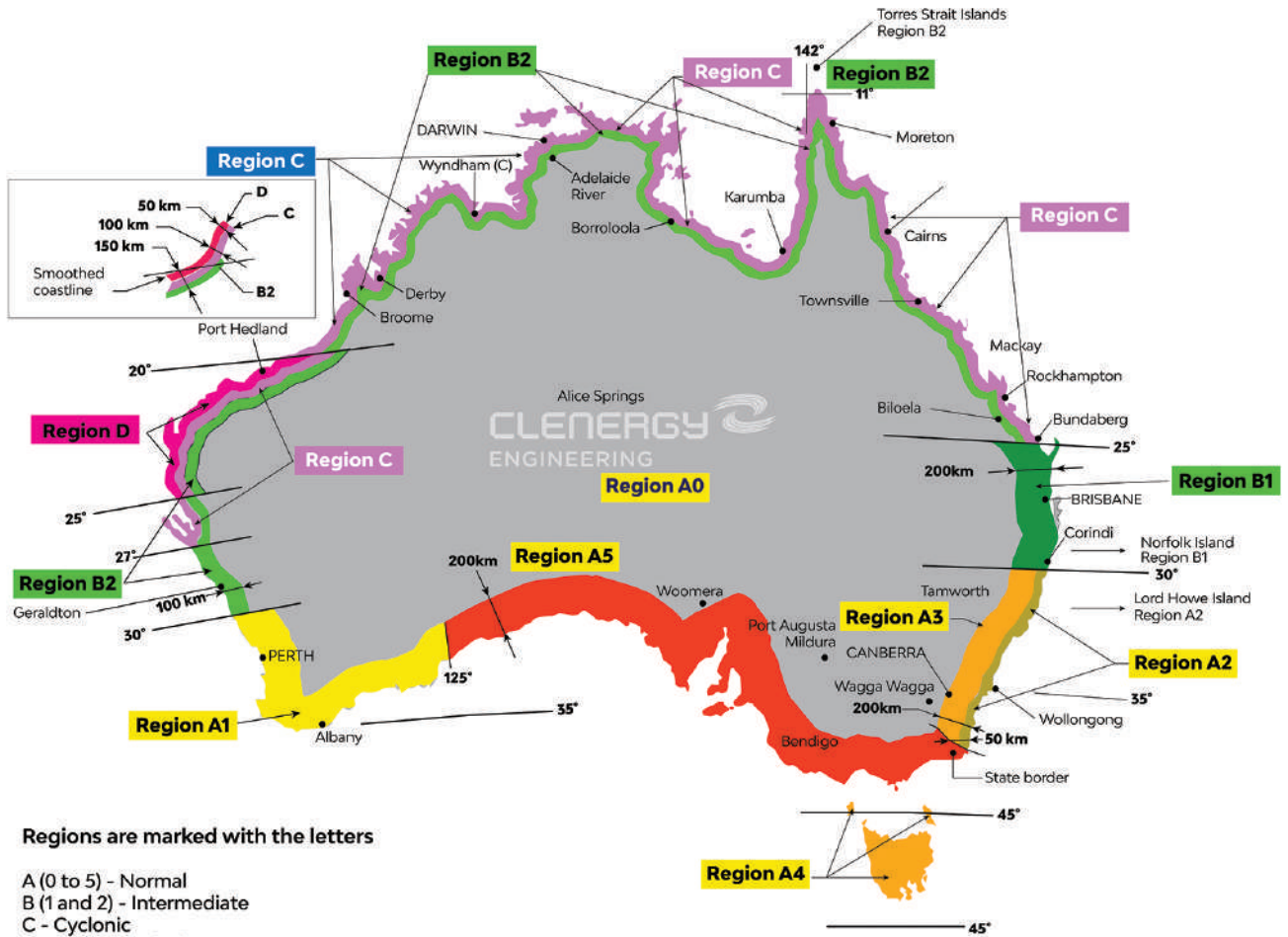

Wind Regions – Australia

Wind regions are pre-defined for the whole of Australia by the Australian Standard 1170.2:2021. Comparing to 1170.2:2011, 2021 version has a lot of changes in wind regions.

- Central Australia is now classified as Wind Region A0 and Terrain Classification 2 instead of Wind Region A4.
- Region A1, previously most of the South coast of Australia, now is divided into Regions A1 and A5.
- Tasmania is now Region A4.
- Region B has been divided into regions B1 and B2. This will affect installations in Northern NSW, Gold Coast, Brisbane, Sunshine Coast, and Gladstone.
- Region B1 was increased to include more inland cities around Brisbane. This will likely mean extra structural requirements such as extra rail for installs.



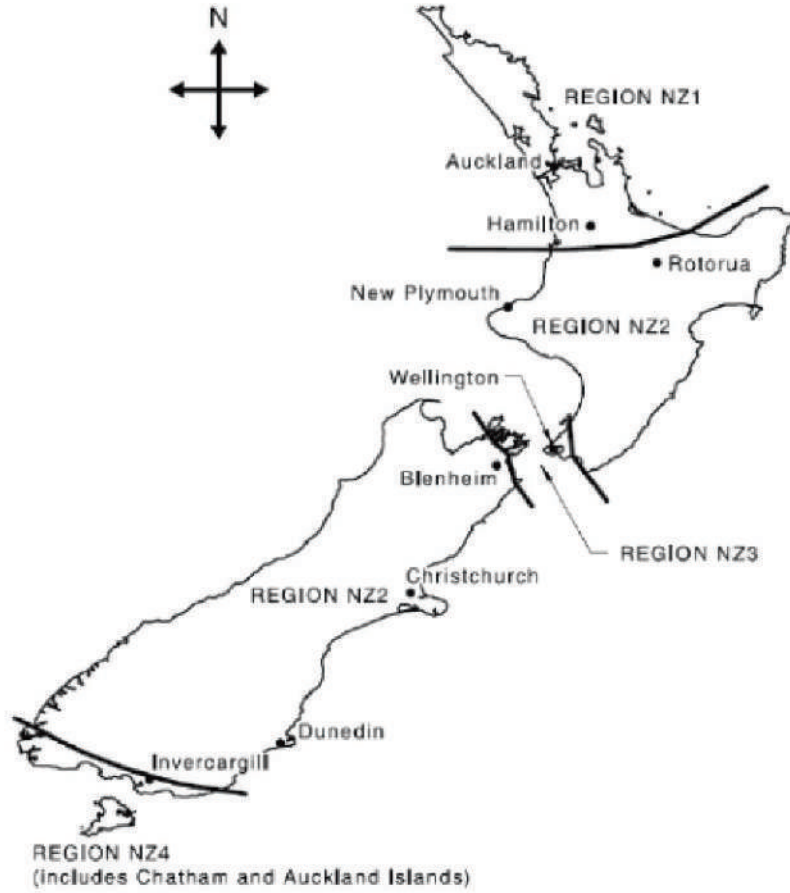







Wind regions map below shows 4 different wind regions in New Zealand: NZ1, NZ2, NZ3 and NZ4.



Wind Regions – New Zealand

# Tools and Components

## Tools

				
<b>Drive Bit</b> (M8 Hexagon Socket Screw)	<b>Electric Drill</b> (ST4.8x16 self-tapping screw & M8 Hexagon Socket Screw)	<b>Torque Wrench</b>	<b>Socket Wrench with 19 mm socket</b>	<b>Measuring Tape</b>
				
<b>String</b>	<b>Marker Pen</b>	<b>Wrench</b>	<b>Electronic Total Station (optional)</b>	<b>Hydraulic Driver</b>

## Components

				
<b>ER-EC-ST</b> End Clamp	<b>ER-IC-ST</b> Inter Clamp	<b>ER-R-T110</b> T-Rail 110	<b>ER-SP-T110</b> Splice for T-110 Rail	<b>ER-RC-T/G</b> Rail Clamp for T-Rail with grounding pins
				
<b>ER-PH-CP/A/B</b> Post Head for C-post with Grounding and Bushing	<b>ER-CP-2800/A</b> C-Post, 2800mm	<b>ER-PB-CP/A</b> post brace for C-Post	<b>ER-PB-CP/D/A</b> Post brace for C-Post on double support with Grounding	<b>ER-S-STIIA/S</b> Support (pre-assembled)

<b>ER-S-STIIA/D</b> Double support (pre-assembled)	<b>ER-CAP-T110</b> Cap for T-110 Rail	<b>ER-CAP-G/A</b> Cap for Square Girder	<b>EZ-GC-ST</b> Grounding Clip	<b>EZ-GL-ST/UC</b> Grounding lug with U-shape copper channel
<b>EZ-GL-AT</b> The Austin – Commercial Grounding Lug with SUS316	<b>C-U/30/46-G</b> Akashi Clamp for Frame Height 30-46mm with Grounding Clip	<b>C-U/30/46</b> Akashi Clamp for Frame Height 30-46mm	<b>BR-R110/EW/G (Optional)</b> PVezRack® East/West Adjustable Bracket for T-Rail 110 with grounding	<b>GE-STA/200</b> Girder Extension, 200 mm

**Note:**

ER-PB-CP/D/A and ER-S-STIIA/D only used on STII double support mounting system.

# System Overview

## Overview of PVezRack® SolarTerrace II-A

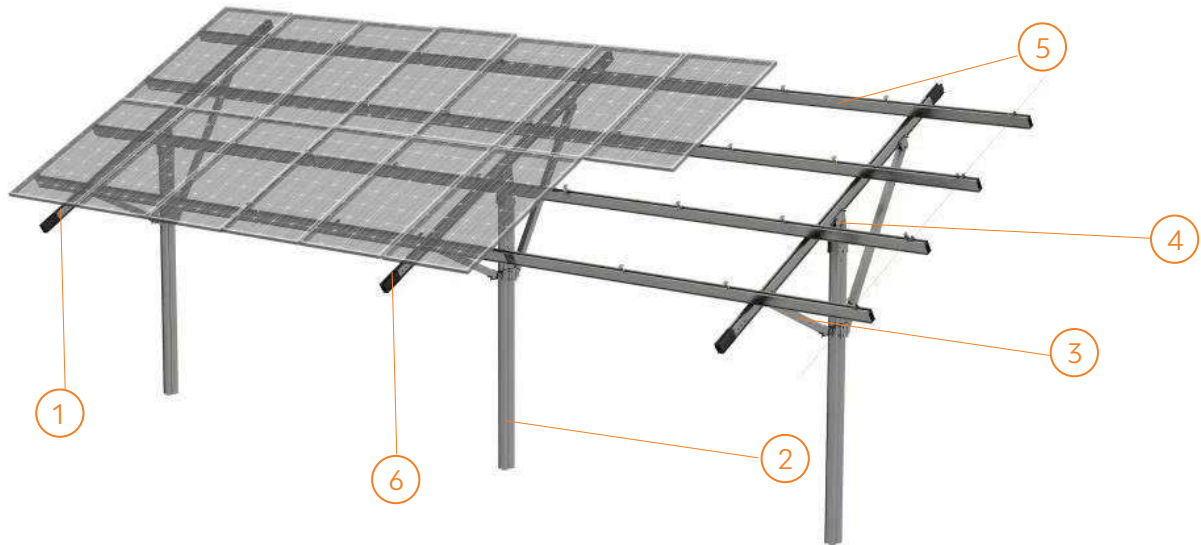

- |  |                                 |
|--|---------------------------------|
| 1. STII-A, Support (pre-assembled)/ Double support (pre-assembled)       | 2. STII-A, C-Post               |
| 3. STII-A, Post brace for C-Post/Post brace for C-Post On double support | 4. STII-A, Post head for C-Post |
| 5. T-Rail 110  | 6. Girder Extension             |

## Precautions during Stainless Steel Fastener Installation

Improper operation may lead to deadlock of Nuts and Bolts. The steps below should be applied to stainless steel nut and bolt assembly to reduce this risk.

### General installation instructions

- (1) Apply force to fasteners in the direction of thread.
- (2) Apply force uniformly, to maintain the required torque.
- (3) Professional tools and tool belts are recommended.
- (4) In some cases, fasteners could be seized over time. As an option, if want to avoid galling or seizing of thread, apply lubricant (grease or 40# engine oil) to fasteners prior to tightening.

## Safe Torques

Please refer to safe torques as shown on page 13. In case power tools are required, Clenergy recommends the use of low speed only. High speed and impact drivers increase the risk of bolt galling (deadlock). If dead lock occurs and you need to cut fasteners, please make sure that there is no load on the fastener before you cut it. Avoid damaging the anodized or galvanized surfaces.

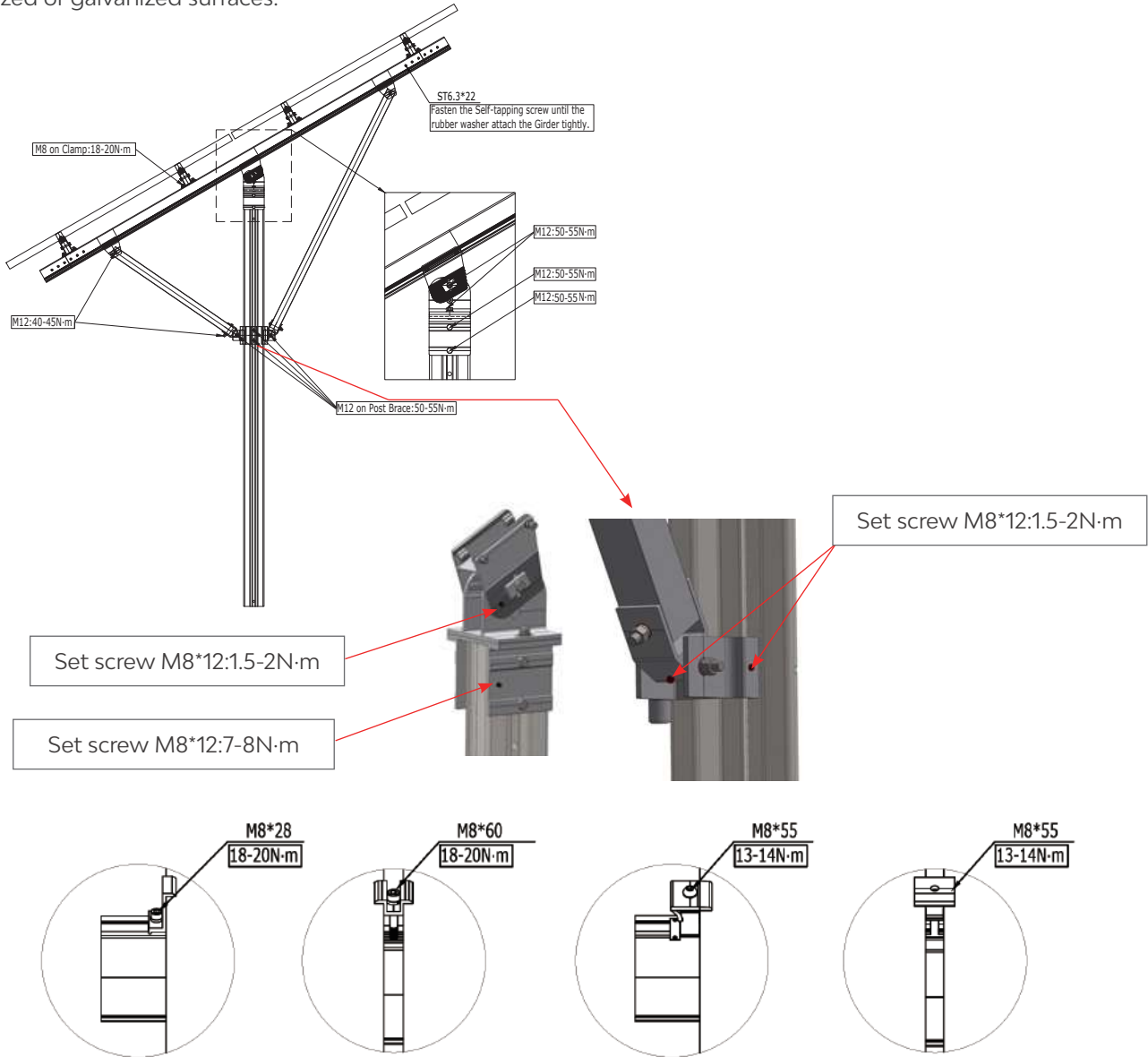

## Installation Dimensions

All drawings and dimensions in this installation guide are a generic reference only. PVezRack® SolarTerrace II-A is to be optimized to suit specific conditions for each project and documented in a construction drawing. As a result, major components of PVezRack® SolarTerrace II-A may be provided in section sizes and lengths that vary from those shown in this guide. The installation process detailed in this instruction guide remains the same regardless of the component size. In case you need to do any on-site modifications or alteration of the system in a way that would be different from the construction drawing please provide marked up drawings/sketches for Clenergy’s review prior modification for comment and approval.

# Installation Instructions

Below are the side view drawings of support for panels up to 1800 x 1400 mm and panels up to 2000 x 1400 mm at 20° and 30° tilt angles.

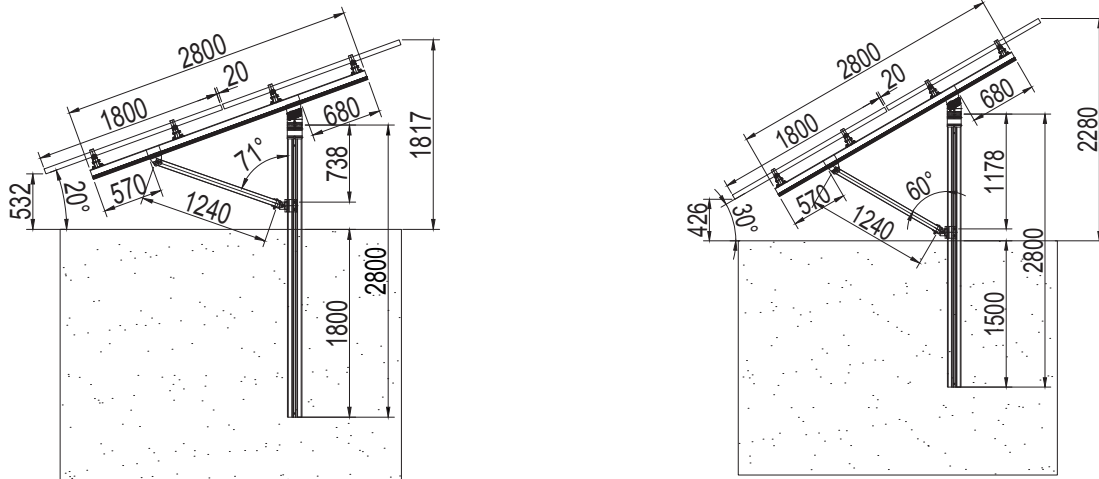

Side view drawings of support for panels up to 1800 x 1400 mm

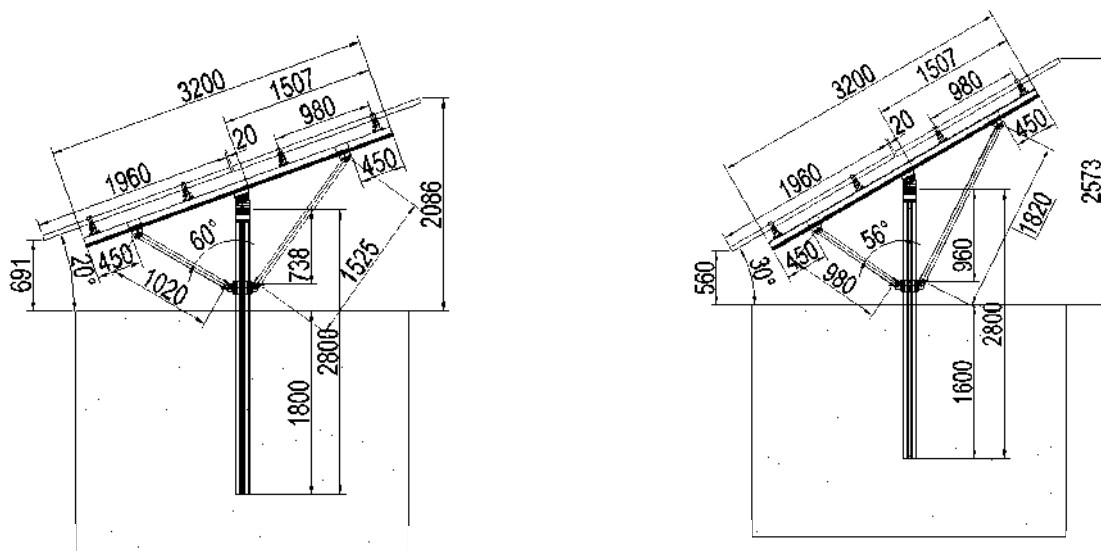

Side view drawings of support for panels up to 2000 x 1400mm

Below is the side view drawing of STII-A Single Support with Girder Extension for panels up to 2000 x 1400 mm at 20° and 30° tilt angle.

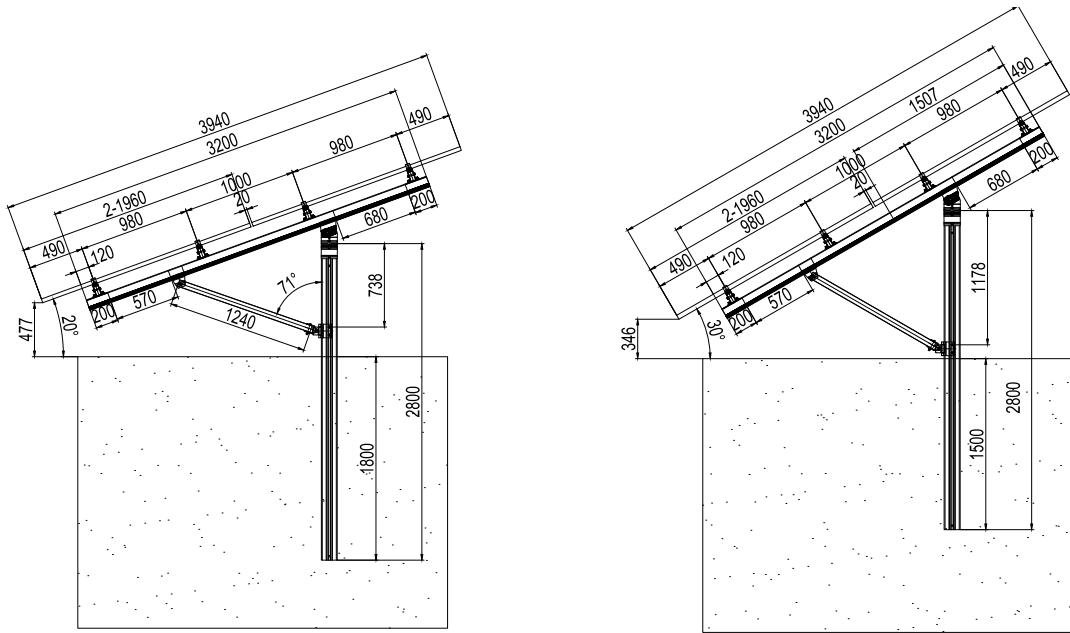

Below is the side view drawing of STII-A Double Support with Girder Extension for panels up to 2400 x 1400 mm at 20° and 30° tilt angle.

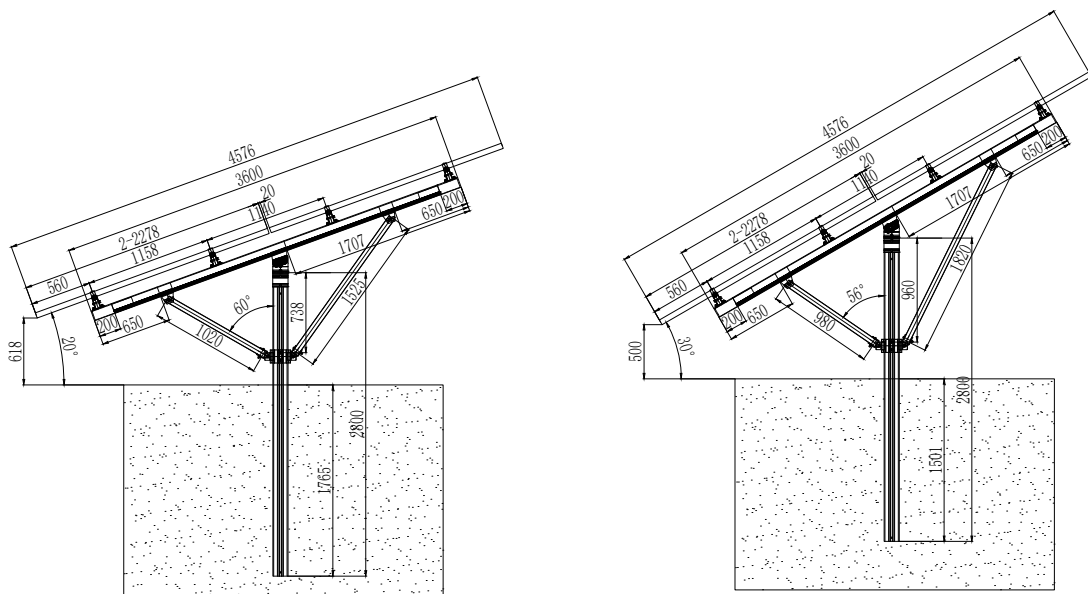

## Range of Adjustment

The tolerances of ramming post as below,

- (1) Post height max:  $\pm 15\text{mm}$  (based on planned height)
- (2) Inclination tolerance E-W max:  $\pm 1^\circ$
- (3) Inclination tolerance N-S max:  $\pm 1^\circ$
- (4) Position E-W max:  $\pm 20\text{mm}$
- (5) Axis tolerance N-S max:  $\pm 20\text{mm}$
- (6) Rotation of post max:  $\pm 2^\circ$
- (7) E-W slope max:  $\pm 2^\circ$

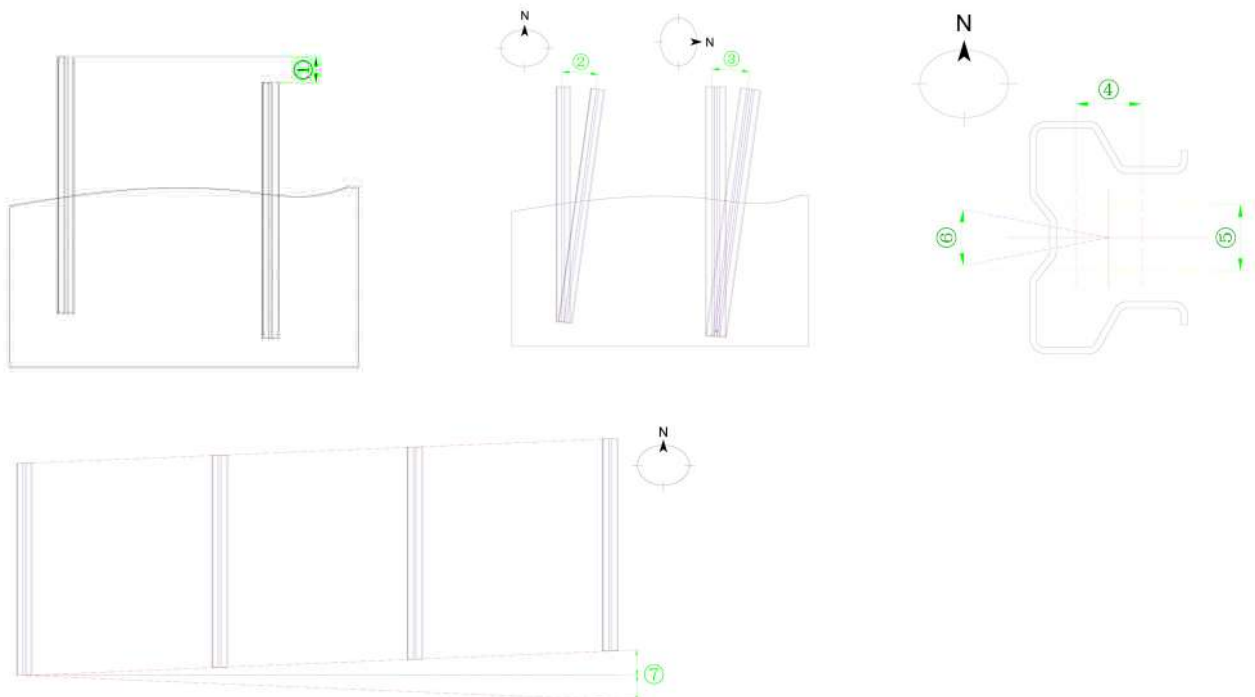

## C-Post Installation

Before starting, check you have the installation tools needed. Position the required components close to the installation location. Make sure that the hydraulic pile driver equipment is suitable for your particular installation.

Mark the line of the post array.

Obtain the maximum allowed distance between posts and the minimum embedment length from the relevant engineering certificate and/or project drawing. If you don't have this document, please contact Clenergy technical support.

Mark the positions of the posts using a string and tape measure or GPS and drive the posts into the ground. Use a sting or a laser tool to make sure all posts are in line and set to the correct height according to the drawing.

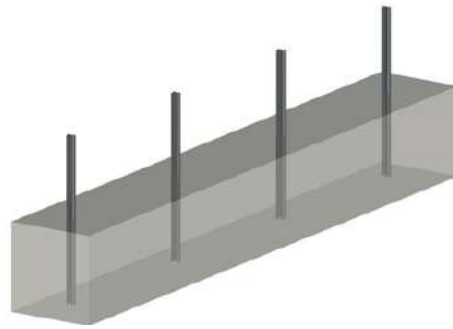

Apply Zinc Coating to upper section of C Post after ramming

**Notes:**

- Apply zinc coating to upper section (circled) of C-Post after piling to repair any damage to the galvanisation caused by ramming.
- The opening of the C-Post faces east or west if the panel faces the north. In case of slope ground installation, the opening of the C-Post is recommended to face the lower ground side to avoid catching the water.

## Post Head Installation

Install the post head and fix it with the two M12 bolts and nuts supplied. Please cross-lock Bolt 1 and Bolt 2 until tighten. To avoid stainless steel galling/seizing apply grease or lubricant if needed.

The spring-loaded clip opening of the Post Head face the same orientation as the solar panels.

Recommended torques:

Bolt 1 with 50-55 N·m

Bolt 2 with 50-55 N·m

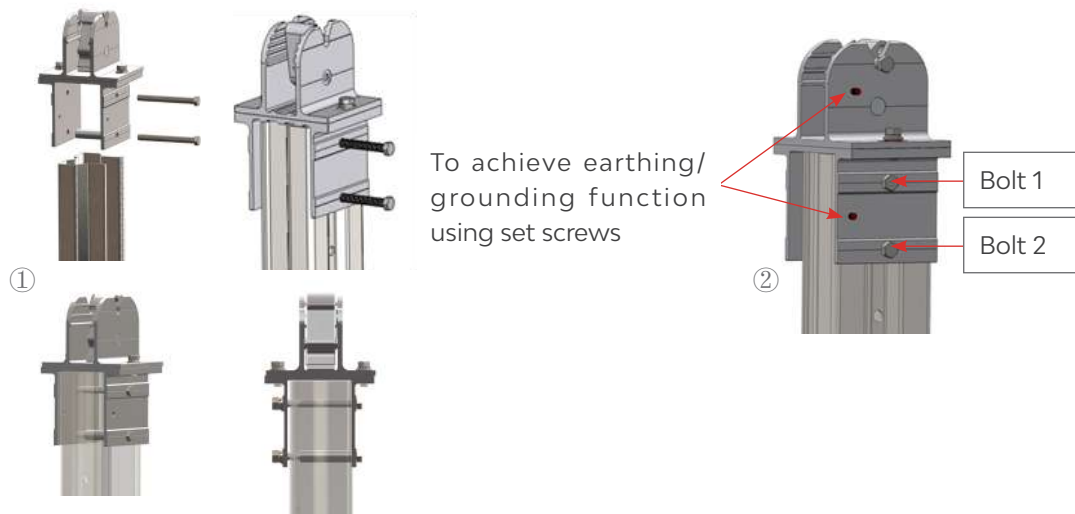

Fig. 1

## Post Brace Installation

Click the Post brace into C-Post as shown and connect with the two M12 bolts and nuts supplied.

Recommended torque:

Bolt M12 50~55N·m

To achieve earthing/  
grounding function using  
set screws

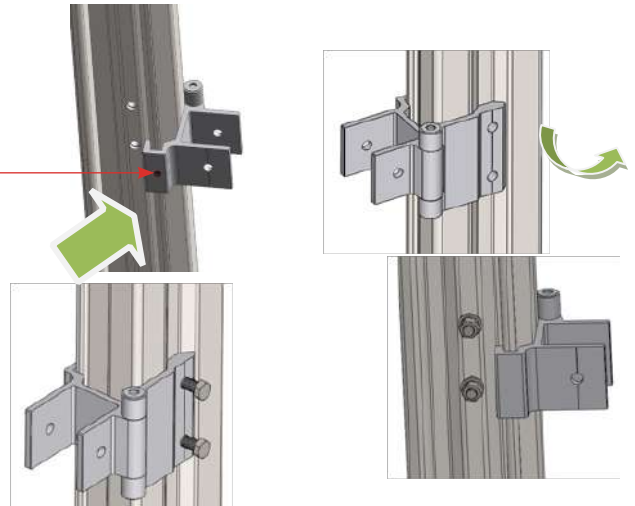

Fig. 2

Post brace on double support installation.

Click two post braces into C-Post as shown and connect with the two M12 bolts and nuts supplied.

Recommended torque:

Bolt M12 50~55N·m



Fig. 3

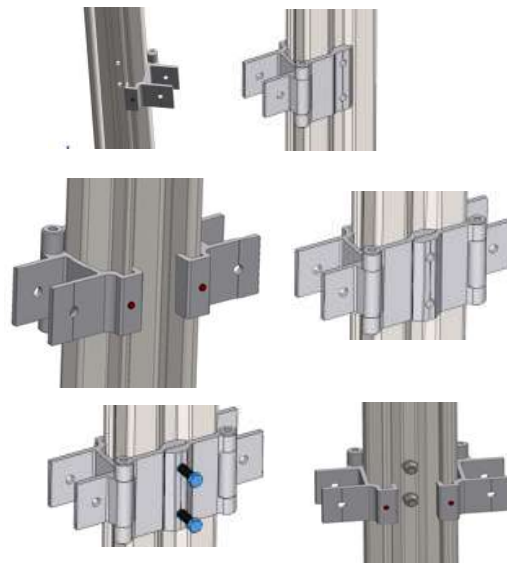

Fig. 4

## Pre-assembled Support Installation

Place the (pre-assembled) support into post head as shown in Fig.5.

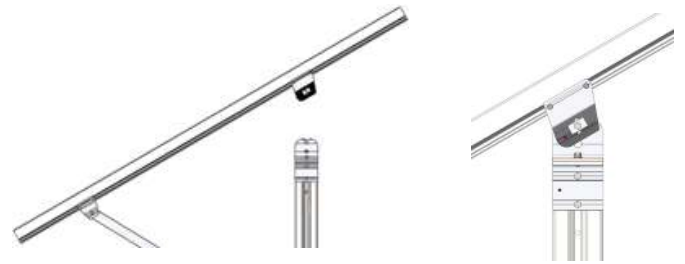

Fig. 5

Connect the brace to the post using the M12 bolt and nut supplied.

Recommended torque:  
M12 : 50-55N·m

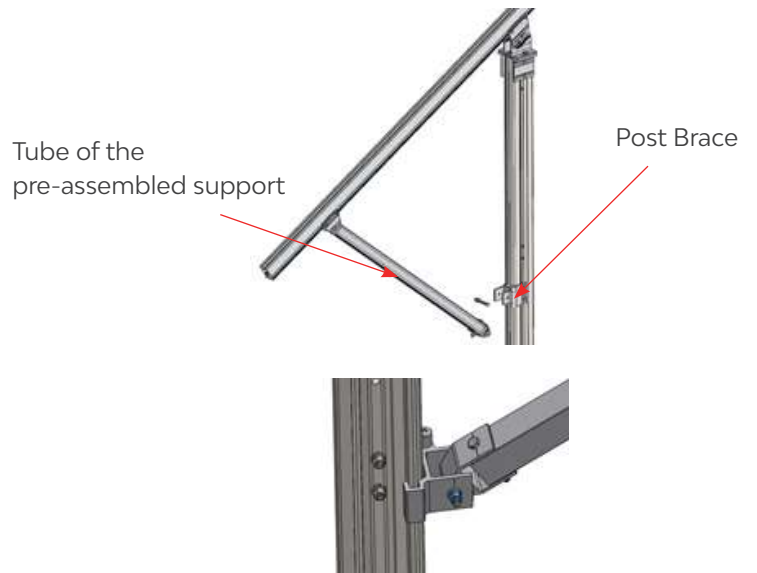

Fig. 6

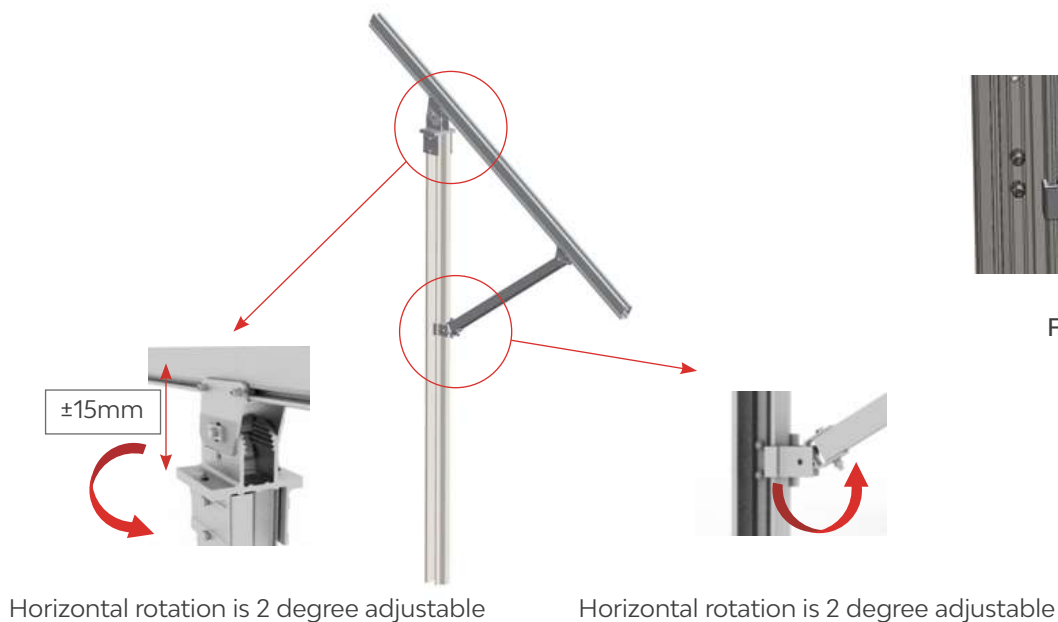

Fig. 7

## Double Support Installation

Place the double support (pre-assembled) into post head. Connect the tubes of the support to the post braces on the post using the M12 bolt and nut supplied.

Recommended torque:  
M12 : 50-55N·m



Fig. 8

### Notes:

(1) The lengths of the two tubes are different. Make sure the shorter one is positioned at the lower part of the tilt as shown.

(2) Connect the shorter Tube Support to post brace.



Fig. 9

(3) Adjust the bolt position of T head to align the post brace to the Tube Support.



Fig. 10

(4) Rotate the orientation of T head to fit the Tube Support to the post brace.



Fig. 11

## System Adjusting

Make final adjustments to Racking System.

Adjust vertically: Loosen Bolt 1 and slide along ellipse hole.

Adjust Tri-groove beam parallel: Loosen Bolt 2 and Bolt 3, turn Post Head slightly, move Al Tube left and right until being parallel. Keep all of Tri-groove beams parallel at same level.

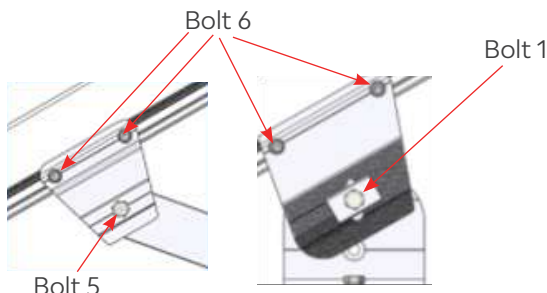

Fig. 12

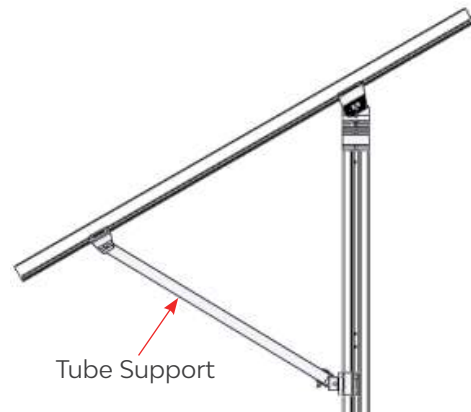

Fig. 13

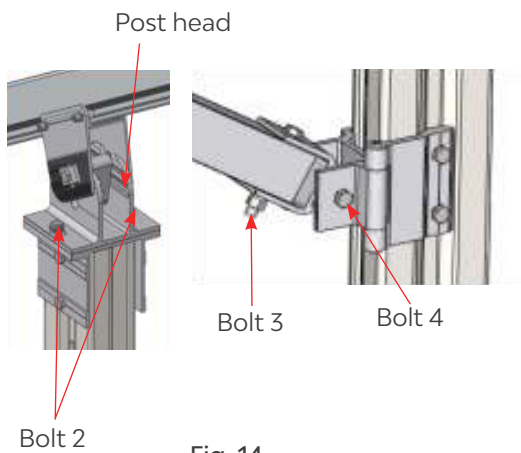

Fig. 14

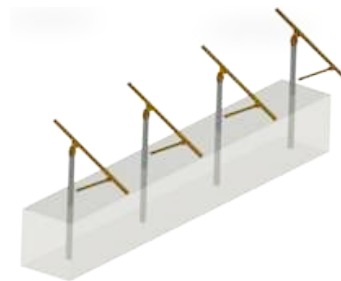

Fig. 15

**Note:**

Make sure all of Tri-groove beams are parallel prior to installation of T-Rails.

Check the torque value of bolt:

- Bolt 1 with 50-55 N·m
- Bolt 2 with 50-55 N·m
- Bolt 3 with 40-45 N·m
- Bolt 4 with 50-55 N·m
- Bolt 5 with 40-45 N·m
- Bolt 6 with 18-20 N·m

## Girder Extension Installation

Insert half of the Splice for Tri-Groove Square Girder into one end of the Girder on the pre-assembled support.

Apply 6 sets of self-drilling screws ST6.3\*22 in the connection position on both sides, the screws have to be fixed according to the figure with dimension on the right. Fasten the screws until their rubber pads are slightly flattened.

Recommended torque for self-tapping screw ST6.3\*22 is 12 N·m.

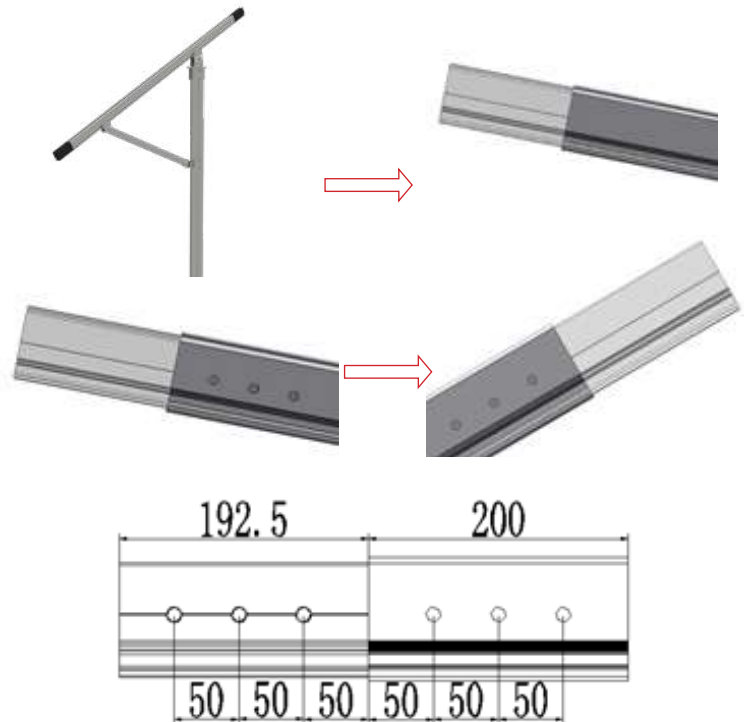

Fig. 16

Insert a 200mm long Tri-Groove Square Girder into Splice and ensure that it will be orientated in the same direction as the existing Tri-Groove Square Girder. Now apply 6 sets of self-tapping screws in the connection positions on both sides. Repeat above step to fix the self-tapping screws.



Fig. 17

The assembled Splice and Girder is shown on the right.



Fig. 18

Fix the Splice for Tri-Groove Square Girder at the other side of the Girder on the pre-assembled support according to the steps above.



Fig. 19

The Girder Extension installation on the pre-assembled support of PVezRack® SolarTerrace II-A is completed as shown on the right.



Fig. 20

**Check the System and Fasten all Bolts with Recommended Torque(please refer to Page 6).**

Recommended Torque:

M8 Bolt: 13N·m;

M8 Nut: 18~20N·m

M12: 40~45N·m

**According to Engineering Drawing, Repeat the Above Operations to Install Other Preassembled Supports**

Ensure all the Tri-Groove Beams of Pre-assembled Support are aligned and all Pre-assembled Supports are parallel to each other.

Now fasten all bolts tightly.

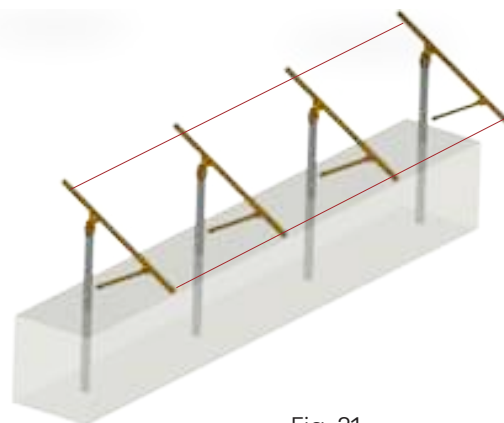

Fig. 21

# T-Rail Installation

## Direct Installation

Slide T-Rails into Pre-assembled rail clamp on Tri-groove beams and use a 6mm Allen key (Hex) to fasten on another side via Rail Clamp for T-Rail.

Recommended Torque:  
M8: 18-20N·m

**Note:**  
Rail clamps can work on both sides with no pre-assembled rail clamp.

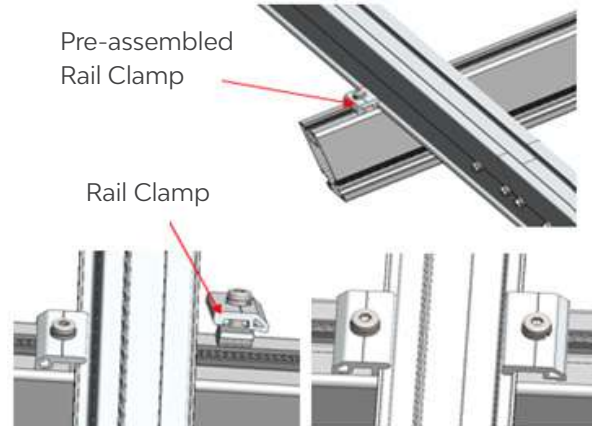

Fig. 22

Determine the necessary length of T-Rail prior to installation, if T-Rail isn't long enough; join two rails via Rail splice as shown before installing the T-Rail as directed in above step.

**Note:**  
Connecting Rails on Structure system is not recommended.

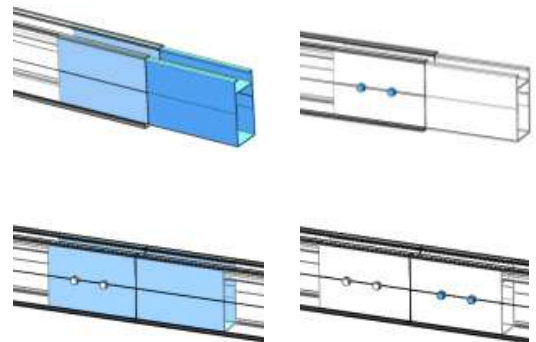

Fig. 23

Racking System installation is completed.



Fig. 24

### East/West Adjustable Bracket Installation (Optional)

Click the pre-assembled East/West Adjustable Bracket into the Tri-Groove Square Girder and adjust properly as shown in Fig. 25. Fasten the M8 bolt slightly with the Allen key.

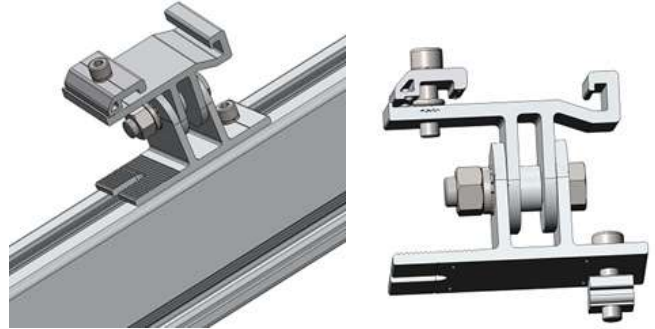

Fig. 25

Click the corrugated shim and Z Moulde/ bolt into the Tri-Groove Square Girder and move them into the opening slot hole of East/West Adjustable Bracket. After the bolt is at the end of slot hole, fasten the M8 bolts slightly as shown in Fig. 26.

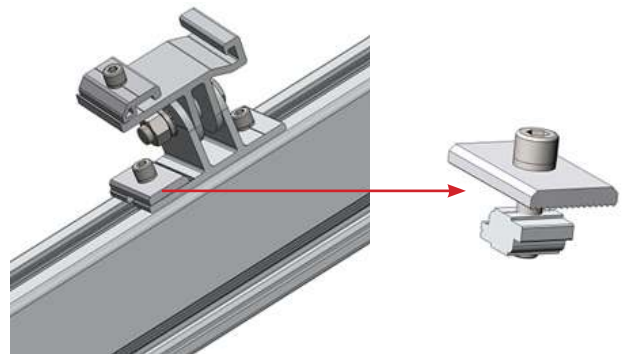

Fig. 26

Repeat above steps to install other East/ West Adjustable Brackets. Adjust all brackets and make the brackets sit at the right positions. Now fasten all M8 bolts tightly within 18-20 N-m as shown in Fig. 27.



Fig. 27

Tilt the T Rail to a certain angle and slide into the groove of East/West Adjustable Brackets of the same height on the Tri-Groove Square Girder. Then use a 6mm Allen key (Hex) to fasten on another side via Rail Clamp for T-Rail. Fasten all the M12 bolts on the East/West Adjustable Brackets.

Recommended Torque:

M8: 18~20 N·m

M12: 50~55 N·m

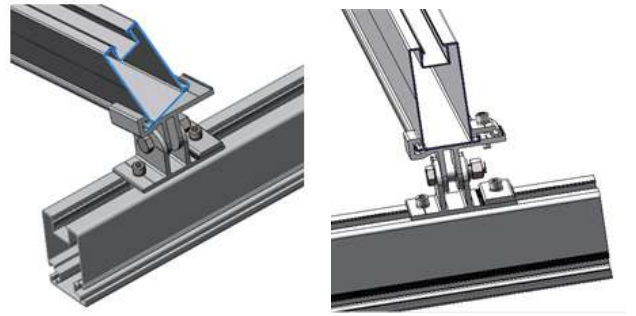

Fig. 28

Repeat the **T Rail Installation** to determine the necessary length of T-Rail prior to installation.

Racking System installation is completed.

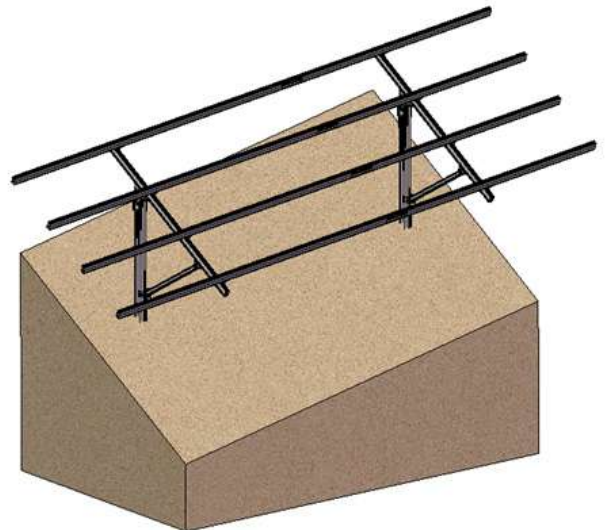

Fig.29

# PV Module Installation

## PV Module Clamps Installation

The guide below is for PV module clamps installation. For PV Module installation, please follow manual provided by the manufacturer.

Before module and clamps installation, it is important to arrange how to position grounding clips to achieve earthing continuity between each PV modules and rails. The Clenergy recommends three different methods for Grounding Clips Layout Arrangement.

### Method 1: "Even and Odd"

- When there is an even number of PV Modules in each row, install the grounding clips at the positions marked X in Fig. 30, where the number of Grounding Clips = number of PV Modules. Figure shows 4 x PV Modules requiring 4 x grounding clips.

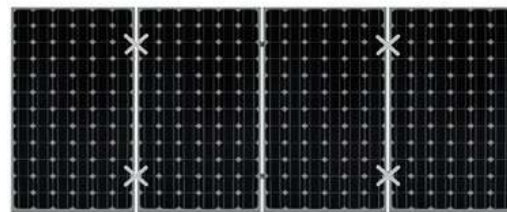

Fig. 30

- When there is an odd number of PV Modules in each row, install grounding clips at positions marked X in Fig. 31, where the number of Grounding Clips = number of PV Modules + 1. Figure shows 5 x PV Modules requiring 6 x grounding clips.

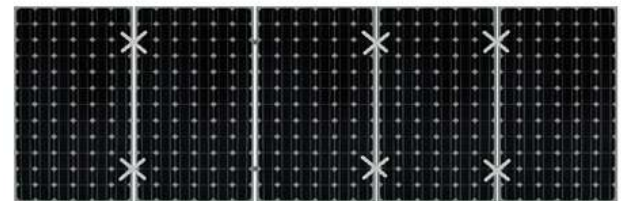

Fig. 31

### Method 2: "Zig Zag"

Install the grounding clips at the positions marked X in Fig. 32, where the number of Grounding Clips = number of PV Modules + 1. Figure shows 5 x PV Modules requiring 6 x grounding clips.

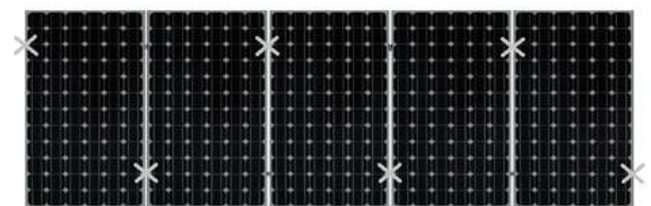

Fig. 32 "Zig Zag" Grounding Clips Layout

### Notes:

- Please consult local PV Module supplier to check whether "Zig Zag" grounding clips layout has any effect on PV modules.
- Grounding clips are not suitable for Dual End Clamp.

### Method 3: "All Inter Clamps"

Install the grounding clips at the positions marked X in Fig. 33, where the number of Grounding Clips = (number of PV Modules -1) x 2. Figure shows 5 x PV Modules requiring 8 x grounding clips.

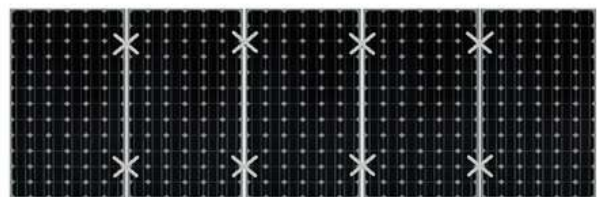

Fig. 33 "All Inter Clamps" Grounding Clips Layout

**Important Notes for any of method above:**

- When replacing defective PV Modules, it is required to replace the grounding clips under the defective PV Modules;
- When removing defective PV Modules, it is required to keep sufficient grounding clips to maintain all other PV modules’ earthing continuity with the rail. It is required to install grounding clips under end clamps when necessary to achieve this;
- For array requiring more than 2 rows of rails, the layout and quantity of grounding clips are the same as those for 2 rows of rails.

There are two types of clamps for PV Modules Installation.

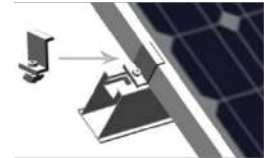

Fig. 34

**Option 1: Standard Inter and End Clamps**

Place the first PV Module on the Rail according to your plan, and fix it in place using the End Clamps. Then fasten lightly as shown in Fig. 34. If arranging grounding clips using “Zig Zag” layout method above, a grounding clip needs to be installed under an end clamp as shown in Fig. 35.



Fig. 35

Slightly lift the PV Module and slide Inter Clamps and Grounding Clips into position. The teeth on Grounding Clip will automatically align when the Inter Clamp is properly installed as shown in Fig. 36.

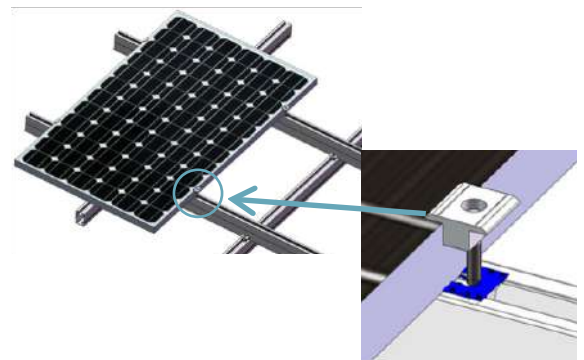

Fig. 36

Loosely place the next framed PV Module into the other side of the Inter Clamp and Grounding Clip as shown in Fig. 37.

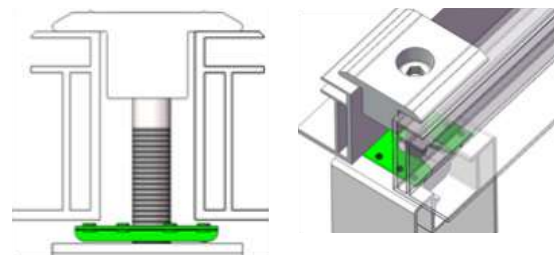

Fig. 37

**Important Notes:**

- To fix the Grounding Clip properly, ensure the frames of PV Modules are completely pressed against End and Inter Clamps and Grounding Clips. Visually check that Grounding Clips are positioned properly;
- Grounding Clips are intended for SINGLE USE ONLY! Only fasten the bolts down with recommended torque of 16-20 N-m when the position of the PV Module is finalized. (Only slightly tighten bolts to keep PV Modules in place prior to the final check).

When using End and Inter clamps, maintain an 18mm vertical and horizontal gap between the two adjacent rows of PV Modules. You can use two Inter Clamps as separation between two PV Modules to achieve this and remove

them after the installation is completed as shown in Fig. 38

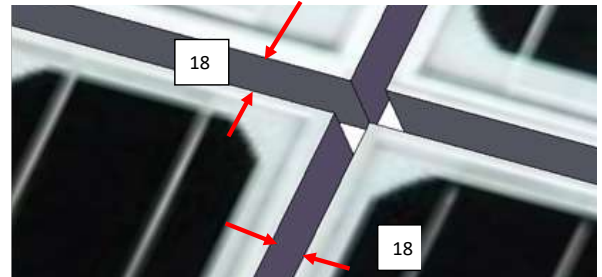

Fig. 38

**Option 2: Akashi Clamps**

Turning the top plate of the Akashi Clamp to switch the functionality between End and Inter Clamp as shown in Fig. 39

Note: Akashi Clamp with part number of C-U/30/46 has no pre-fitted grounding clip and Akashi Clamp with part number of C-U/30/46-G has pre-fitted grounding clip. Please use one of grounding clips layout arrangement methods above to position them correctly.

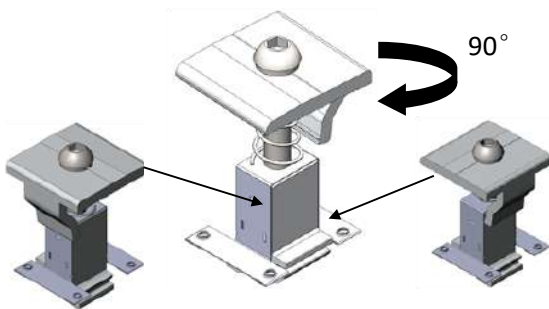

Fig. 39

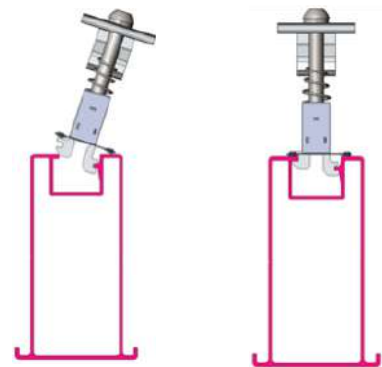

Fig. 40

Note: Before clicking in, make sure there is enough room between two "claws" of the module otherwise it needs to screw up the bolt as shown in Fig. 41.

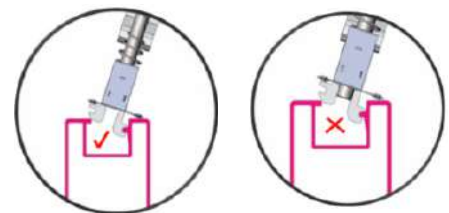

Fig. 41

Place the first PV Module on the Rails and apply the Akashi Clamp as the End Clamp and fasten slightly. Make sure the frame of the PV Module is fully in contact with the Akashi Clamp as shown in Fig. 42 and 43. Visually check the Akashi Clamp and PV module are properly installed.

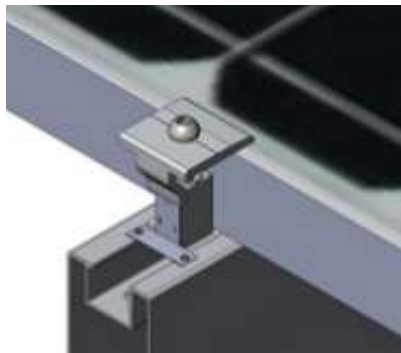

Fig. 42

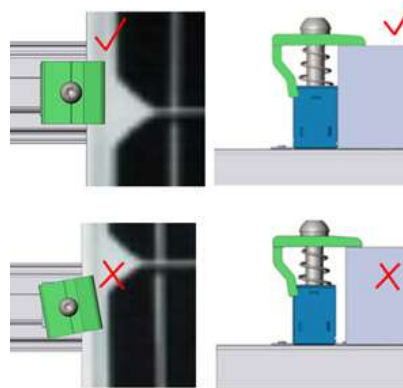

Fig. 43

When using as an Inter Clamp, click the Akashi Clamp into the rail channel and slightly lift the framed PV Module to ensure the Grounding Clip is properly positioned as shown in Fig. 44.

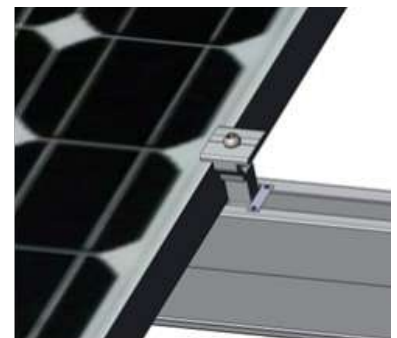

Fig. 44

Loosely place the next framed PV Module into the other side of the Akashi Clamp. Ensure the Grounding Clip is properly positioned, and the frame of the PV Module is in proper contact with Akashi Clamp as shown in Fig. 45 and 46.

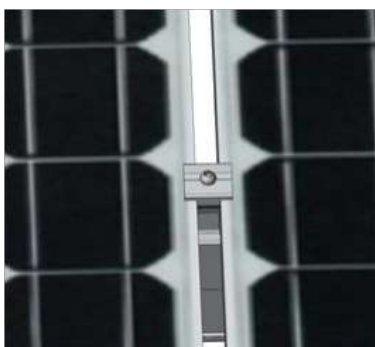

Fig. 45

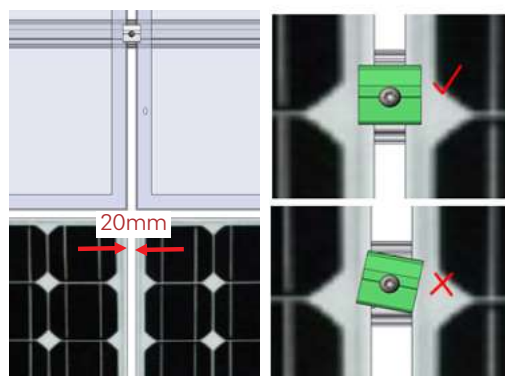

Figure 46

**Note:** The gap between two adjacent PV Modules generated by Akashi Clamp is 20mm. The recommend torque for Akashi Clamp as Inter and End Clamp is 13~14 N·m.

## Grounding Lug Installation

The Clenergy provides two types of grounding lugs to meet different installation requirements, such as required earthing cable sizes. In order to meet the minimum earthing electrical resistance requirement by AS/NZS 5033:2021, it is required to install one Grounding Lug per row of rail.

### A. Grounding Lug with U-shape Copper Channel (EZ-GL-ST/UC)

The recommended fasten torque of the bolt M8\*25 is 16~20 N·m.

Once grounding lug fixing with rail, insert U-Shape Copper Channel into grounding lug as shown in Figure 47. Strip earthing cable (the maximum size is 10 mm<sup>2</sup>), insert the conductor into the Copper Channel and tighten the bolt M6\*14 with 5~6 N·m to ensure the earthing cable is tight.

Note: Please check the electrical resistance between rail and earthing cable conductor to ensure the bonding is made.

There are three options for Grounding Lug installation.

#### Option 1

Fix the Grounding Lug into the top channel of Rail as shown in Fig. 48.

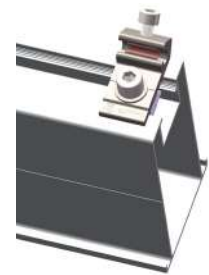

Fig. 47

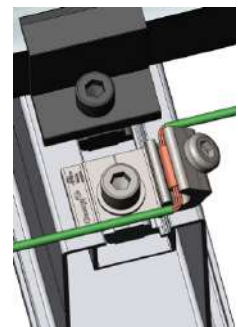

Fig. 48

#### Option 2

Fix the Grounding Lug into the top channel of Rail where just under the PV Module as shown in Fig. 49. Total height of grounding lug allows installation under 30 mm high PV module.

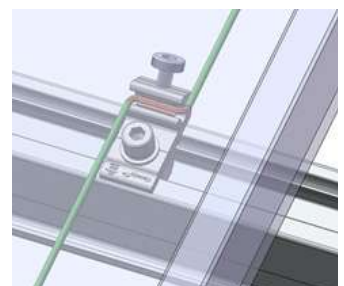

Fig. 49

## B. The Austin – Commercial Grounding Lug (EZ-GL-AT)

Place the grounding lug on top of rail and ensure z module is on the right position and lug sits flush on the rail surface as shown in Fig. 50. Do not fully tighten the bolt.

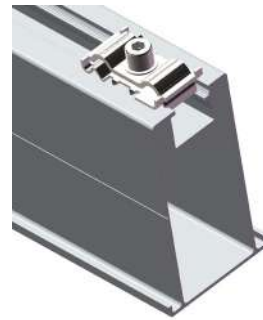

Fig. 50

There are two channels to fit different earthing cables.

Channel one is for earthing cable of 4, 6, 10 and 16 mm<sup>2</sup> and channel two is for earthing cable of 25, 35, 50 mm<sup>2</sup>

Lift up one side of top plate of lug, insert the conductor of earthing cable into channel and tighten the bolt to ensure lug is well fixed on the rail and earthing cable is tight.

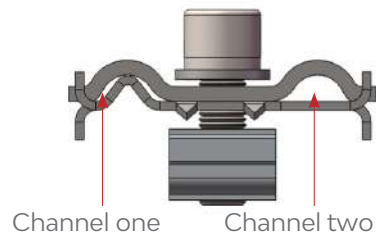

Fig. 51

Note:

Please check the electrical resistance between rail and earthing cable conductor to ensure the bonding is made.

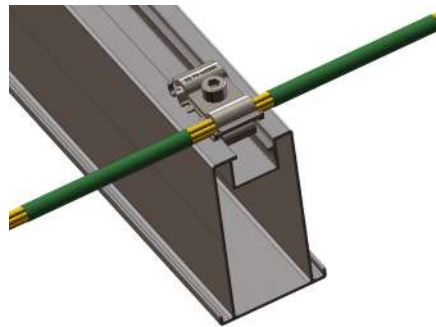

Fig. 52

There are two options for Grounding Lug installation.

### Option 1

Fix the Commercial Grounding Lug into the top channel of Rail as shown in Fig. 53a and b.

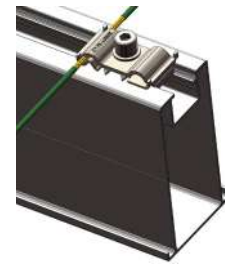

Fig. 53a Installed in channel one

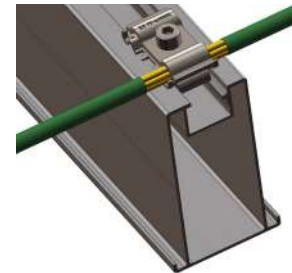

Fig. 53b Installed in channel two

### Option 2

Fix the Commercial Grounding Lug into the top channel of Rail where is under the PV Module as shown in Fig. 54. The height of grounding lug above the rail is less than 20 mm.

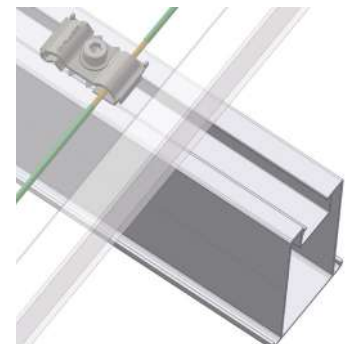

Fig. 54

Now the installation is completed as shown in Fig. 55. Please recheck all Bolts and fasten them tightly according to the recommended torque. The PV Modules should be aligned correctly with 18mm gaps when using End and Inter Clamps and 20mm gaps when using Akashi Clamps.

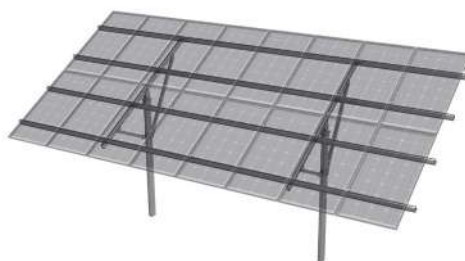

Fig. 55

# AU Certification



## Structural Certification Clenergy PV-ezRack SolarTerrace II-A (STII-A)

**Within Australia**

**For:** Clenergy Australia  
Suite 1/10 Duerdin Street  
Clayton, VIC 3168

Clenergy Reference Number: CL-997-Y

**Job No.** 11398-1  
**Date:** 10/09/2024

Gamcorp Pty Ltd  
ACN: 665 643 658 | ABN: 86 665 643 658

**Gamcorp**  
+61 3 9543 2211  
www.gamcorp.com.au  
info@gamcorp.com.au

# Document Control Record

A person using Gamcorp documents or data accepts the risk of:

- a. Using the documents or data in electronic form without requesting and checking them for accuracy against the original hard copy version
- b. Using the documents or data for any purpose not agreed to in writing by Gamcorp.

Document Control						
<b>Report Title</b>		General Compliance Letter STII-A				
<b>Document ID</b>		11398-1/LvS	<b>Job No.</b>		11398-1	
<b>File Path</b>		G:\Shared drives\11000\11300 - 11399\11398\03 Certification				
<b>Client</b>			<b>Client Contact</b>		Geza Anderson	
<b>Rev</b>	<b>Date</b>	<b>Revision Details</b>	<b>Prepared By</b>	<b>Author</b>	<b>Verifier</b>	<b>Approver</b>
0	28/03/2023	First Issue	NK/LvS	LvS	AA	LvS
1	25/05/2023	Client's comments	LvS	LvS	-	LvS
2	25/08/2023	References, titles, Gamcorp name, Reference to NCC etc	LvS	LvS	-	LvS
3	10/09/2024	Textual item detail (post)	LvS	LvS	-	LvS
<b>Current Revision</b>			3			

Approval			
Author Signature		Approver Signature	
Name	L. Van Spaandonk	Name	L. Van Spaandonk
Title	Structural Engineer	Title	Principal Engineer

**COPYRIGHT:** The concepts and information contained in this document are the property of Gamcorp Pty Ltd. Use or copying of this document in whole or in part without the written permission of Gamcorp constitutes an infringement of copyright.

**LIMITATION:** This report has been prepared on behalf of and for the exclusive use of Gamcorp Pty Ltd's Client, and is subject to and issued in connection with the provisions of the agreement between Gamcorp Pty Ltd and its Client. Gamcorp Pty Ltd accepts no liability or responsibility whatsoever for or in respect of any use of or reliance upon this report by any third party.

# PV Array Frame Structural Certification

## SolarTerrace II-A Installation in Australia

Gamcorp Pty Ltd, being Structural Engineers within the meaning of Australian Building Regulations, have carried out a structural design check of the PV-ezRack SolarTerrace II-A with single support, double supports, single support with extended girder, and double support with extended girder - for installation within Australia. The design check has been based on the information in the *PV-ezRack SolarTerrace II-A Planning and Installation Guide* and schematic drawings of the system components, provided by Clenergy Australia.

Component Description	Part Number
T-Rail 110	ER-R-T110/XX
PV-ezRack SolarTerraceII-A, Single Support (Pre-assembled) adjustable 20°/25°/30°, with 2800mm Girder	ER-S-STIIA/S30
PV-ezRack SolarTerraceII-A, Double Support (Pre-assembled) adjustable 20°/30°, with 3200mm Girder	ER-S-STIIA/D20 or 30
PV-ezRack SolarTerraceII-A, C-Post	ER-CP-XXXX/A
Splice for T-Rail 110	ER-SP-T110
PV-ezRack SolarTerraceII-A, Post Head for C-post	ER-PH-CP/A, ER-PH-CP/A/B
PV-ezRack SolarTerraceII-A, Post Brace for C-Post on Single Support	ER-PB-CP/A, ER-PB-CP/A
PV-ezRack SolarTerraceII-A, Post Brace for C-Post on Double Support	ER-PB-CP/D/A, ER-PB-CP/D/A
PV-ezRack Inter Clamp	ER-IC-STXX
PV-ezRack End Clamp	ER-EC-STXX
PV-ezRack Akashi Clamp for Frame Height 30-46mm with Grounding Clip	C-U/30/46-G
PV-ezRack Akashi Clamp for Frame Height 30-46mm	C-U/30/46
PV-ezRack T-Rail Clamp with Grounding	ER-RC-T/G
PV-ezRack Girder Extension for SolarTerrace-A (II and III) 200mm	GE-STA/200
East/West Adjustable - Bracket for T-Rail 110	BR-R110/EW, BR-R110/EW/G

We find the SolarTerrace II-A to be structurally adequate and compliant with NCC 2022 and all relevant Australian Standards listed below - for installation in Australia, provided the conditions listed within this certificate are adhered to:

- NCC and relevant standards:
  - Section B of Vol1, NCC 2022;
  - AS/NZS1170.0:2002 – Structural design actions, Part 0: General principles;
  - AS/NZS1170.1:2002 (R2016) – Structural design actions, Part 1: Permanent, imposed, and other actions;
  - AS/NZS1170.2:2021 – Structural design actions, Part 2: Wind actions:
    - Wind Terrain Category 2;
    - Wind average recurrence interval of 100 years (ultimate), 25 years (serviceability);
    - Wind regions A, B1, B2, C & D;
    - Ms=1, Mt=1, Md=1;
- PV panels width up to 1400mm, length (Lp) refer further pages, mass 15kg/m<sup>2</sup>;
- Tilt angles considered 20 and 30 degrees for wind regions A and B1, and only 20 degrees for wind regions B2, C, and D. Other tilt angles are also possible but with other frame dimensions;
- Materials Strength calculated: steel post 400MPa (Q355B), aluminium members 240MPa (AL6005-T5).

## CONTENT

### Part 1.

SolarTerrace II-A (**Single** Support) installation in Australia (solar panels **up to 1800 mm** long) (**superseding** letter **6396-1**)

### Part 2.

SolarTerrace II-A (**Double** Support) installation in Australia (solar panels **up to 2000 mm** long) (**superseding** letter **6396-2**)

### Part 3.

SolarTerrace II-A (**Double** Support with **Extension**) installation in Australia (solar panels **2001 - 2400 mm** long) (**superseding** letter **7375-1**)

### Part 4.

SolarTerrace II-A (**Single** Support with **Extension**) installation in Australia (solar panels **up to 2000 mm** long) (**superseding** letter **7802-1**)

## Tables

### Table 1.

Maximum Frame Spacing (S) and Footing Options for Standard STII-A (Single Support) with solar panels up to 1800 mm long.

### Table 2.

Maximum Frame Spacing (S) and Footing Options for Standard STII-A (Double Support) with solar panels up to 2000 mm long.

### Table 3.

Factors (to multiply values S and D from table 2) for Installation of STII-A (Double Support, with extended girder = 200+3200+200mm) with solar panels 2001 - 2400 mm long.

Example of finding maximum spacing and footing option, using Table 3.

### Table 4.

Factors (to multiply values S and D from Table 1) for Installation of STII-A (Single Support, with extended girder = 200+2800+200mm) with solar panels up to 2000 mm long.

### Table 5.

Explanation of the adopted soil classes.

## Pictures

Fig. 1. Example Cross Frame for table 1, tilt 20 degrees, driven post

Fig. 2. As Fig. 1, but post embedded in the concrete pier

Fig. 3. As Fig. 1, but tilt 30 degrees

Fig. 4. As Fig. 2, but tilt 30 degrees

Fig. 5. Example Cross Frame for table 2, tilt 20 degrees, driven post

Fig. 6. As Fig. 5, but post embedded in the concrete pier

Fig. 7. As Fig. 5, but tilt 30 degrees

Fig. 8. As Fig. 6, but tilt 30 degrees

Fig. 9. Example Cross Frame for table 4, tilt 20 degrees, driven post

Fig. 10. As Fig. 9, but tilt 30 degrees

## Appendices

A1. Explanation of Importance Levels

A2. Map of Australian Wind Regions

## Part 1. SolarTerrace II-A (Single Support) installation in Australia (solar panels up to 1800 mm long)

**Table 1.** Maximum Frame Spacing (S) and Footing Options for Standard STII-A (Single Support) with solar panels up to 1800 mm long.

Wind Region	Region A		Region B1		Region B2	Region C	Region D
Panels tilt angle, degrees	<b>20</b>	<b>30</b>	<b>20</b>	<b>30</b>	<b>20</b>	<b>20</b>	<b>20</b>
Wind speed, m/s	41		48			56	66
Panel clearance (Cp), mm, max/min	532 / 395	600 / 426	532 / 395	600 / 426	532 / 395	532 / 395	532 / 395
Max/Min post height above the ground, mm, from Clenergy	1000 / 863	1399 / 1300	1000 / 863	1399 / 1300	1000 / 863	1000 / 863	1000 / 863
Spacing (S), m	<b>3.50</b>	<b>3.30</b>	<b>3.40</b>	<b>2.70</b>	<b>3.30</b>	<b>2.95</b>	<b>1.95</b>
Max Vertical Uplift Reaction, kN	10.4	14.3	14.5	16.6	15.7	19.6	18.4
Max Vertical Down Reaction, kN	11.3	14.1	14.3	15.1	15.0	17.6	15.6
Max Horizontal Reaction, kN	4.4	9.3	5.9	10.4	6.3	7.7	7.1
Max Moment at GL, kNm	10.1	17.9	13.4	20.0	14.3	17.4	15.9
<b>Soil Class</b>	<b>Driven post minimum depth (D), m</b>						
Compact sand	1.45	N/A	1.63	N/A	1.68	1.82	1.75
Medium dense sand	1.90	N/A	N/A	N/A	N/A	N/A	N/A
Very Stiff to Hard clays	1.50	N/A	1.69	N/A	1.74	1.90	1.83
Firm to Stiff Clays	N/A	N/A	N/A	N/A	N/A	N/A	N/A
<i>Driven post maximum depth: based on standard 2800 mm long post (m), from Clenergy</i>	<b>1.937</b>	<b>1.500</b>	<b>1.937</b>	<b>1.500</b>	<b>1.937</b>	<b>1.937</b>	<b>1.937</b>
<b>Soil Class</b>	<b>Post embedded in concrete pier: 300 mm diameter concrete piers minimum depth (D), m</b>						
Compact sand	0.95	1.20	1.05	1.25	1.10	1.15	1.10
Medium dense sand	1.20	1.50	1.35	1.60	1.35	1.50	1.45
Very Stiff to Hard clays	0.95	1.20	1.05	1.25	1.10	1.15	1.15
Firm to Stiff Clays	1.30	1.75	1.50	1.85	1.55	1.70	1.60

### Notes:

1.1. This certification is applicable for Standard STII-A (single support) with dimensions as shown in Figures 1-4 and the panel clearance above the ground (Cp) as mentioned in Table 1. Contact Gamcorp for customised STII-A or if the site conditions are not covered by the soil classes considered in this assessment;

1.2. The length of the T-Rails overhang shall be up to 0.4x installed spacing;

1.3. For **25** degrees tilt angle the spacing and footing options can be interpolated between 20° and 30°. Cp = 411-589 mm, post height = 1200-1085 mm AG, post depth 1715 mm maximum;

1.4. For concrete piers foundation we recommend using 25 MPa strength plain concrete;

1.5. The post shall be embedded in the pier for approximately 0.6-0.9 of the pier depth;

1.6. Other pier sizes are possible. In the case of ø250mm concrete pier, the pier depth will increase approx. 20% compared to the ø300mm pier. Contact Gamcorp for the pier depths of other pier diameters.

## Part 2. SolarTerrace II-A (Double Support) installation in Australia (solar panels up to 2000 mm long)

**Table 2.** Maximum Frame Spacing (S) and Footing Options for Standard STII-A (Double Support) with solar panels up to 2000 mm long.

Wind Region	Region A		Region B1		Region B2	Region C	Region D
Panels tilt angle, degrees	20	30	20	30	20	20	20
Wind speed, m/s	41		48			56	66
Panel clearance (Cp), mm, max/min	691 / 554	560 / 445	691 / 554	560 / 445	691 / 554	691 / 554	691 / 554
Max/Min post height above the ground, mm, from Clenergy	1000 / 863	1200 / 1085	1000 / 863	1200 / 1085	1000 / 863	1000 / 863	1000 / 863
Spacing (S), m	3.30	2.80	3.20	2.10 (2.00*)	3.10	2.60	1.85 (1.80*)
Max Vertical Uplift Reaction, kN	11.1	13.7	15.3	14.5	16.5	19.3	19.5
Max Vertical Down Reaction, kN	11.6	13.1	14.7	12.9	15.4	17.0	16.3
Max Horizontal Reaction, kN	4.6	8.8	6.2	9.0	6.6	7.5	7.4
Max Moment at GL, kNm	12.1	19.4	16.0	19.9	17.1	19.5	19.2
<b>Soil Class</b>	<b>Driven post minimum depth (D), m</b>						
Compact sand	1.55	N/A	1.75	N/A	1.79	1.89	1.88
Medium dense sand	N/A	N/A	N/A	N/A	N/A	N/A	N/A
Very Stiff to Hard clays	1.60	N/A	1.85	N/A	1.87	N/A	N/A
Firm to Stiff Clays	N/A	N/A	N/A	N/A	N/A	N/A	N/A
<i>Driven post maximum depth: based on standard 2800 mm long post (m), from Clenergy</i>	1.937	1.715	1.937	1.715	1.937	1.937	1.937
<b>Soil Class</b>	<b>Post embedded in concrete pier: 300 mm diameter concrete piers minimum depth (D), m</b>						
Compact sand	1.00	1.20	1.10	1.20	1.15	1.20	1.20
Medium dense sand	1.25	1.55	1.40	1.55	1.45	1.55	1.55
Very Stiff to Hard clays	1.00	1.25	1.15	1.25	1.15	1.20	1.20
Firm to Stiff Clays	1.40	1.75	1.60	1.80	1.65	1.75	1.75

### Notes.

2.1. This certification is applicable for Standard STII-A (double support) with dimensions as shown in Figures 5-8 and the panel clearance above the ground (Cp) as mentioned in Table 2. Contact Gamcorp for customised STII-A or if the site conditions are not covered by the soil classes considered in this assessment;

2.2. Refer Note 1.2;

2.3. (\*) in the table applicable for the cases when using Clenergy East-West adaptor (if different to the spacing without adaptor);

2.4. Refer Note 1.4;

2.5. Refer Note 1.5;

2.6. Refer Note 1.6.

### Part 3. SolarTerrace II-A (Double Support with Extension) installation in Australia (solar panels 2001 - 2400 mm long)

**Table 3.** Factors (to multiply values S and D from table 2) for Installation of STII-A (Double Support, with extended girder = 200+3200+200mm) with solar panels 2001 - 2400 mm long.

panel dimensions 1400mm x (mm)			wind A 20 degree	wind A 30 degree	wind B1 20 degree	wind B1 30 degree	wind B2 20 degree	wind C 20 degree	wind D 20 degree
Reduction factor for frame spacing	2001-2100		1.00	0.93	1.00	0.90	1.00	0.92	0.92
	2101-2200		0.97	0.86	0.97	0.81	0.95	0.85	0.84
	2201-2300		0.94	0.79	0.92	0.71	0.90	0.77	0.76
	2301-2400		0.91	0.71	0.88	0.62	0.82	0.67	0.68
Increasing factor for minimum post ramming depth*	2001-2100	Compact sand	1.04	N/A	1.03	N/A	1.04	1.01	1.00
	2101-2200		1.06	N/A	1.05	N/A	1.05	1.00	0.99
	2201-2300		1.08	N/A	1.06	N/A	1.06	0.99	0.98
	2301-2400		1.10	N/A	1.07	N/A	1.05	0.97	0.97
Increasing factor for minimum concrete pier depth*	2001-2100	Compact sand	1.00	1.00	1.09	1.00	1.04	1.00	1.00
		Medium dense sand	1.12	1.03	1.07	1.03	1.03	0.97	0.97
		Very Stiff to Hard clays	1.10	0.96	1.04	0.96	1.04	1.00	1.00
		Firm to Stiff Clays	1.14	1.03	1.06	0.94	1.03	0.97	0.97
	2101-2200	Compact sand	1.00	1.00	1.09	1.00	1.04	1.00	1.00
		Medium dense sand	1.12	1.03	1.07	1.03	1.03	0.97	0.97
		Very Stiff to Hard clays	1.10	0.96	1.04	0.96	1.04	1.00	1.00
		Firm to Stiff Clays	1.14	1.03	1.06	0.94	1.03	0.97	0.97
	2201-2300	Compact sand	1.00	1.00	1.09	1.00	1.04	1.00	1.00
		Medium dense sand	1.12	1.03	1.07	1.03	1.03	0.97	0.97
		Very Stiff to Hard clays	1.10	0.96	1.04	0.96	1.04	1.00	1.00
		Firm to Stiff Clays	1.14	1.03	1.06	0.94	1.03	0.97	0.97
	2301-2400	Compact sand	1.00	1.00	1.09	1.00	1.04	1.00	1.00
		Medium dense sand	1.12	1.03	1.07	1.03	1.03	0.97	0.97
		Very Stiff to Hard clays	1.10	0.96	1.04	0.96	1.04	1.00	1.00
		Firm to Stiff Clays	1.14	1.03	1.06	0.94	1.03	0.97	0.97

Note(\*): In some cases the pier depth is decreased as a result of the smaller spacing.

Example see next page.

**Example of finding maximum spacing and footing option, using Table 3.**

Case:

Wind Region	Region A
Panel length, mm	2300
Tilt, degrees	20
Soil	Compact sand

Find in Table 2:

Spacing, m	3.30
Driven post depth, m	1.55
Pier ø300 depth, m	1.00

Find in Table 3:

panel dimensions 1400mm x (mm)			wind A 20 degree	From Table 2	Result for 2300mm panel
Reduction factor for frame spacing	2001-2100		1.00		
	2101-2200		0.97		
	<b>2201-2300</b>		<b>0.94</b>	<b>3.30</b>	<b>3.10</b>
	2301-2400		0.91		
Increasing factor for minimum <b>post ramming</b> depth	2001-2100	<b>Compact sand</b>	1.04		
	2101-2200		1.06		
	<b>2201-2300</b>		<b>1.08</b>	<b>1.55</b>	<b>1.67</b>
	2301-2400		1.10		
Increasing factor for minimum <b>concrete pier</b> depth	2001-2100	Compact sand	1.00		
		Medium dense sand	1.12		
		Very Stiff to Hard clays	1.10		
		Firm to Stiff Clays	1.14		
	2101-2200	Compact sand	1.00		
		Medium dense sand	1.12		
		Very Stiff to Hard clays	1.10		
		Firm to Stiff Clays	1.14		
	<b>2201-2300</b>	<b>Compact sand</b>	<b>1.00</b>	<b>1.00</b>	<b>1.00</b>
		Medium dense sand	1.12		
		Very Stiff to Hard clays	1.10		
		Firm to Stiff Clays	1.14		
	2301-2400	Compact sand	1.00		
		Medium dense sand	1.12		
		Very Stiff to Hard clays	1.10		
		Firm to Stiff Clays	1.14		

**Part 4. SolarTerrace II-A (Single Support with Extension) installation in Australia (solar panels up to 2000 mm long)**

**Table 4.** Factors (to multiply values S and D from Table 1) for Installation of STII-A (Single Support, with extended girder = 200+2800+200mm) with solar panels up to 2000 mm long.

panel dimensions 2000x1400		wind A 20 degree	wind A 30 degree	wind B1 20 degree	wind B1 30 degree	wind B2 20 degree	wind C 20 degree	wind D 20 degree
Reduction factor for frame spacing		0.71	0.55	0.74	0.59	0.7	0.53	0.62
Increasing factor for minimum post ramming depth*	Compact sand	0.92	N/A	0.93	N/A	0.91	0.81	0.86
	Compact sand	0.95	0.83	0.95	0.88	0.87	0.91	0.91
Increasing factor for minimum concrete pier depth*	Medium dense sand	0.92	0.87	0.96	0.88	0.87	0.83	0.90
	Very Stiff to Hard clays	0.95	0.83	0.95	0.88	0.87	0.87	0.87
	Firm to Stiff Clays	0.92	0.86	0.93	0.86	0.82	0.88	0.88

Note(\*): In some cases the footing depth is decreased as a result of the required smaller spacing. Other pier sizes are possible. In the case of ø250mm concrete pier, the pier depth will increase approx. 20% compared with the ø300mm pier. Contact Gamcorp for the pier depths of other pier diameters.

**Table 5.** Explanation of the adopted soil classes

	ABC (Allowable Bearing Capacity), kPa
Compact sand	≥ 300
Medium dense sand	150 - 300
Very Stiff to Hard clays	300 - 600
Firm to Stiff Clays	100 - 150

The maximum frame spacing is based on the structural capacity of the frame in the perimeter zone of an array. We recommend performing tests on-site for the geotechnical capacity of the driven post. The spacing may need to be decreased to achieve the available geotechnical capacity of the driven post following the test results.

Construction is to be carried out strictly in accordance with the instruction manual. This work was designed in accordance with the provisions of Australian Building Regulations and in accordance with sound, widely accepted engineering principles. This certification **excludes** assessment of the members' durability/corrosion and PV panels. This certification is valid till **May 31, 2025**, unless any of the relevant Australian Standards becomes updated before the due date.

Yours faithfully,  
Gamcorp Pty Ltd



**L. Van Spaandonk**  
Principal Engineer  
FIEAust CPEng NER 5038980

Frames pictures (examples):

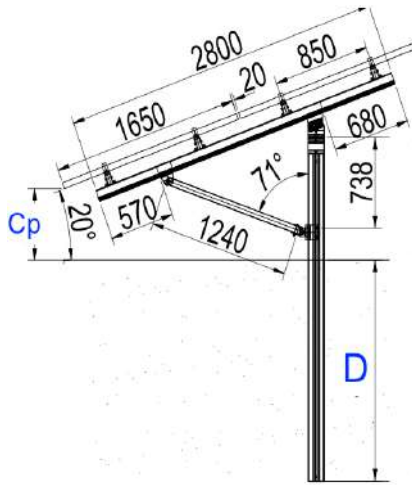

Fig. 1

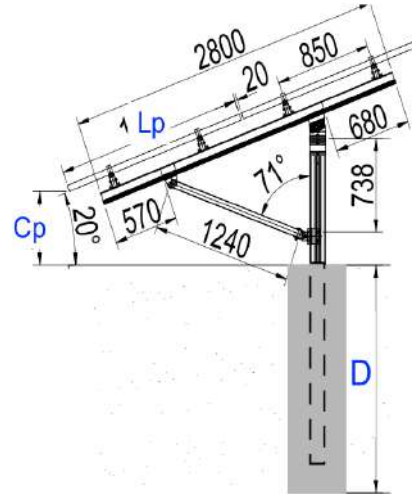

Fig. 2

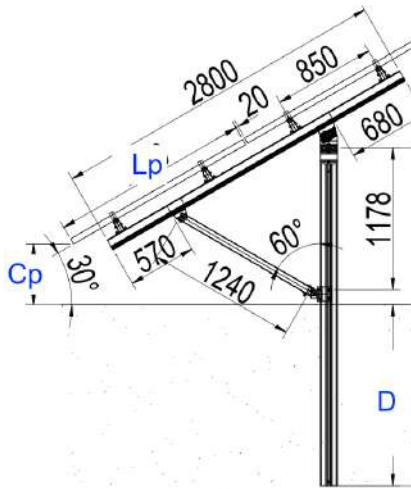

Fig. 3

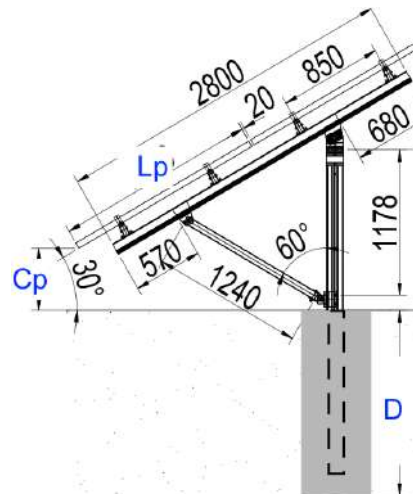

Fig. 4

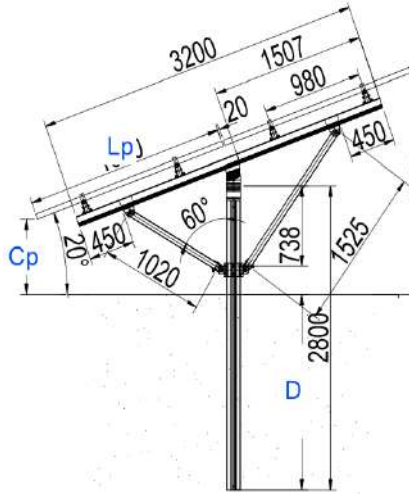

Fig. 5

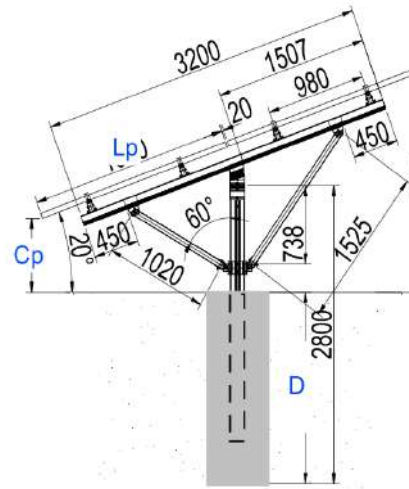

Fig. 6

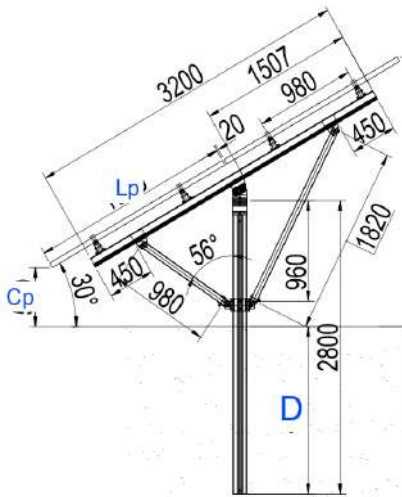

Fig. 7

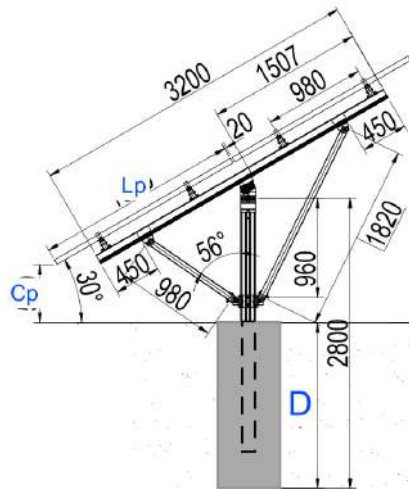

Fig. 8

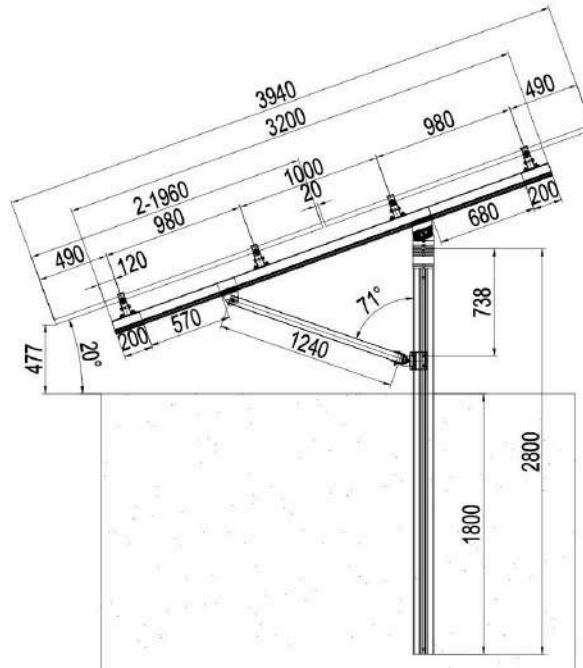

Fig. 9

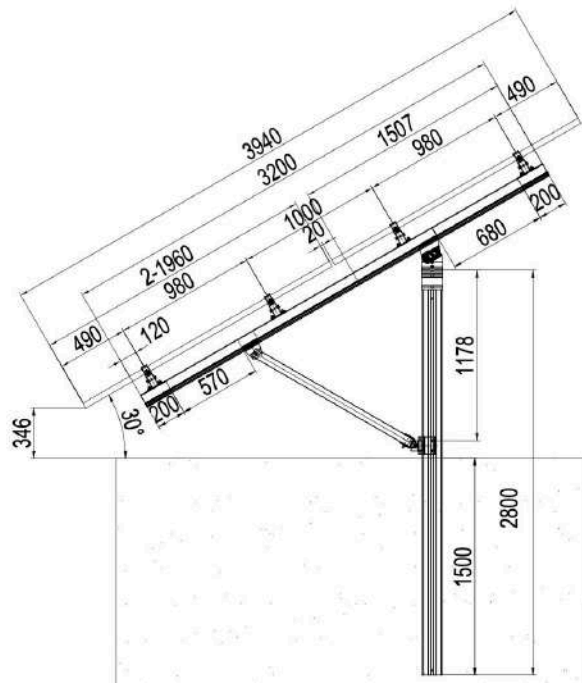

Fig. 10

## Appendices

### A1. Explanation of Importance Level

(from AS/NZS-1170\_0-2002 - Structural design actions - General principles - amendments 1-5 incorporated)

**TABLE F1  
STRUCTURE TYPES FOR IMPORTANCE LEVELS**

Consequences of failure	Description	Importance level	Comment
Low	<b>Low</b> consequence for loss of human life, <i>or</i> <b>small or moderate</b> economic, social <i>or</i> environmental consequences	1	Minor structures (failure not likely to endanger human life)
Ordinary	<b>Medium</b> consequence for loss of human life, <i>or</i> <b>considerable</b> economic, social <i>or</i> environmental consequences	2	Normal structures and structures not falling into other levels
High	<b>High</b> consequence for loss of human life, <i>or</i> <b>very great</b> economic, social or environmental consequences	3	Major structures (affecting crowds)
		4	Post-disaster structures (post-disaster functions or dangerous activities)
Exceptional	Circumstances where reliability must be set on a case by case basis	5	Exceptional structures

**TABLE F2  
ANNUAL PROBABILITY OF EXCEEDANCE OF THE DESIGN EVENTS  
FOR ULTIMATE LIMIT STATES**

Design working life	Importance level	Design events for safety in terms of annual probability of exceedance		
		Wind	Snow	Earthquake (see Note 1)
Construction equipment (e.g. props, scaffolding, braces and similar)	2	1/100	1/50	Not required (see Note 3)
5 years or less (only for structures whose failure presents no risk to human life, see Note 2)	1	1/25	1/25	Not required (see Note 3)
	2	1/50	1/50	
	3	1/100	1/100	
25 years	1	1/100	1/25	Not required (see Note 3)
	2	1/200	1/50	
	3	1/500	1/100	
	4	1/1000	1/250	
50 years	1	1/100 (non-cyclonic)	1/100	1/250
	1	1/200 (cyclonic)		
	2	1/500	1/150	1/500
	3	1/1000	1/200	1/1000
100 years or more	4	1/2500	1/500	1/2500
	1	1/500	1/200	1/250
	2	1/1000	1/250	1/1000
	3	1/2500	1/500	1/2500
	4	(see Paragraph F3)	(see Paragraph F3)	(see Paragraph F3)

Map of Australian Wind Regions

(from AS/NZS-1170\_2-2021 - Structural design actions - Part 2: Wind actions)

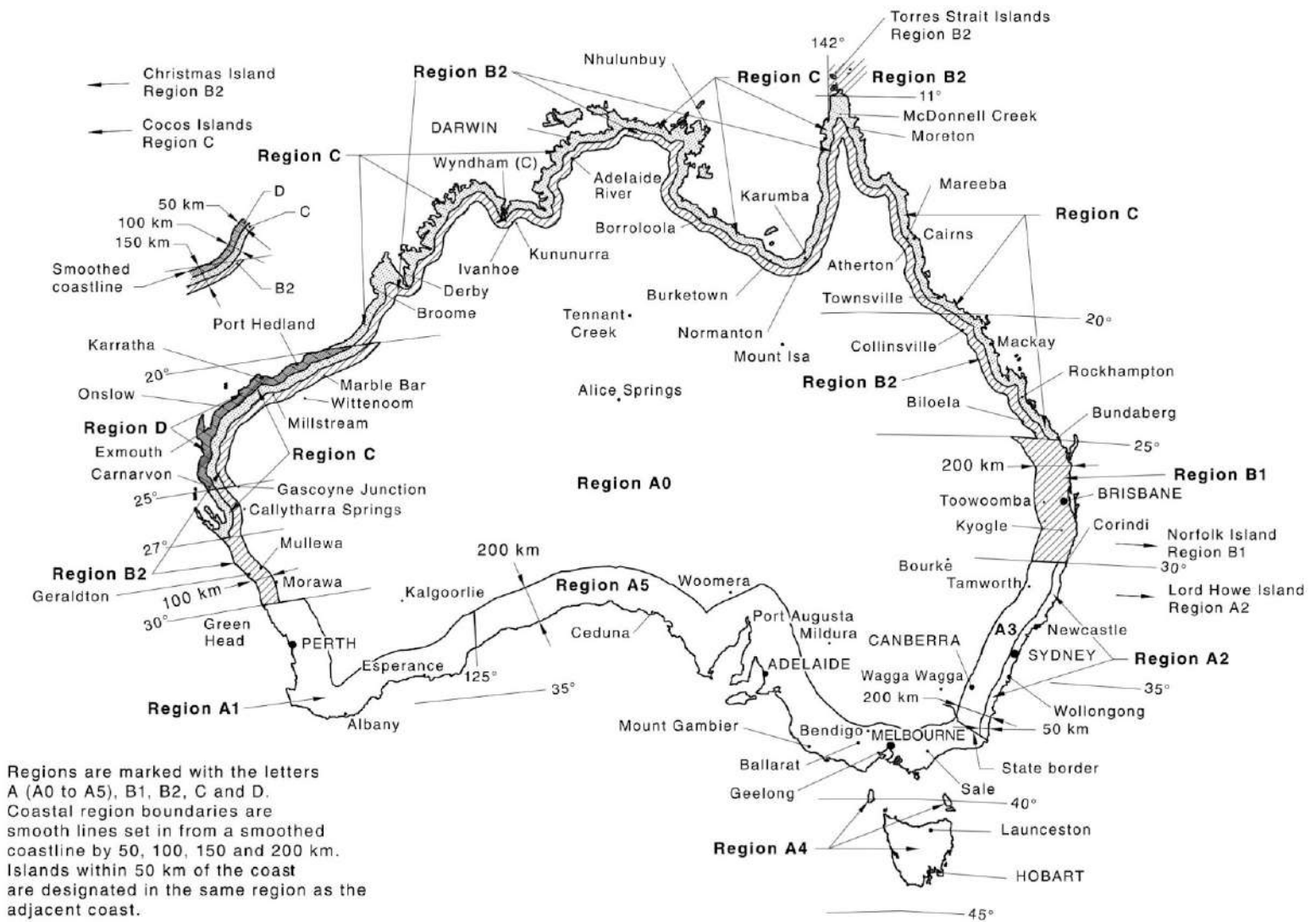

**Figure 3.1(A) — Wind regions — Australia**

# NZ Certification



## Structural Certification Clenergy PV-ezRack SolarTerrace II-A (STII-A)

**Within New Zealand**

**For** Clenergy Australia  
Suite 1/10 Duerdin Street  
Clayton, VIC 3168

Clenergy Reference Number: CL-997-Y

**Job No.** 12822-1  
**Date:** 10/09/2024

Gamcorp Pty Ltd  
ACN: 665 643 658 | ABN: 86 665 643 658

**Gamcorp**  
+61 3 9543 2211  
www.gamcorp.com.au  
info@gamcorp.com.au

# Document Control Record

A person using Gamcorp documents or data accepts the risk of:

- a. Using the documents or data in electronic form without requesting and checking them for accuracy against the original hard copy version
- b. Using the documents or data for any purpose not agreed to in writing by Gamcorp.

Document Control						
<b>Report Title</b>		General Compliance Letter STII-A				
<b>Document ID</b>		12822-1/LvS	<b>Job No.</b>		12822-1	
<b>File Path</b>		G:\Shared drives\12000\12800 - 12899\12822\03 Certification				
<b>Client</b>			<b>Client Contact</b>		Geza Anderson	
		Clenergy Australia PTY LTD				
Rev	Date	Revision Details	Prepared By	Author	Verifier	Approver
0	11/05/2023	Draft	LvS	LvS	AA/YK	-
1	25/08/2023	Comments to 11398, Gamcorp name	LvS	LvS	-	LvS
2	10/09/2024	Textual item detail (post)	LvS	LvS	-	LvS
<b>Current Revision</b>		2				

Approval			
Author Signature		Approver Signature	
Name	L. Van Spaandonk	Name	L. Van Spaandonk
Title	Structural Engineer	Title	Principal Engineer

**COPYRIGHT:** The concepts and information contained in this document are the property of Gamcorp Pty Ltd. Use or copying of this document in whole or in part without the written permission of Gamcorp constitutes an infringement of copyright.

**LIMITATION:** This report has been prepared on behalf of and for the exclusive use of Gamcorp Pty Ltd's Client, and is subject to and issued in connection with the provisions of the agreement between Gamcorp Pty Ltd and its Client. Gamcorp (Melbourne) Pty Ltd accepts no liability or responsibility whatsoever for or in respect of any use of or reliance upon this report by any third party.

# PV Array Frame Structural Certification

## SolarTerrace II-A Installation in New Zealand

Gamcorp Pty Ltd, being Structural Engineers within the meaning of Australian Building Regulations, have carried out a structural design check of the PV-ezRack SolarTerrace II-A with single supports, double supports and single supports with extensions within within New Zealand. The design check has been based on the information in the *PV-ezRack SolarTerrace II-A Planning and Installation Guide* and schematic drawings of the system components, provided by Clenergy Australia.

Component Description	Part Number
T-Rail 110	ER-R-T110/XX
PV-ezRack SolarTerraceII-A, Single Support (Pre-assembled) adjustable 20°/25°/30°, with 2800mm Girder	ER-S-STIIA/S30
PV-ezRack SolarTerraceII-A, Double Support (Pre-assembled) adjustable 20°/30°, with 3200mm Girder	ER-S-STIIA/D20 or 30
PV-ezRack SolarTerraceII-A, C-Post	ER-CP-XXXX/A
Splice for T-Rail 110	ER-SP-T110
PV-ezRack SolarTerraceII-A, Post Head for C-post	ER-PH-CP/A, ER-PH-CP/A/B
PV-ezRack SolarTerraceII-A, Post Brace for C-Post on Single Support	ER-PB-CP/A, ER-PB-CP/A
PV-ezRack SolarTerraceII-A, Post Brace for C-Post on Double Support	ER-PB-CP/D/A, ER-PB-CP/D/A
PV-ezRack Inter Clamp	ER-IC-STXX
PV-ezRack End Clamp	ER-EC-STXX
PV-ezRack Akashi Clamp for Frame Height 30-46mm with Grounding Clip	C-U/30/46-G
PV-ezRack Akashi Clamp for Frame Height 30-46mm	C-U/30/46
PV-ezRack T-Rail Clamp with Grounding	ER-RC-T/G
PV-ezRack Girder Extension for SolarTerrace-A (II and III) 200mm	GE-STA/200
East/West Adjustable - Bracket for T-Rail 110	BR-R110/EW, BR-R110/EW/G

We find the SolarTerraceII-A to be structurally sufficient for installation in New Zealand, based on the following conditions:

- Wind Loads to **AS/NZS 1170.2:2021**;
  - Wind Terrain Category **2**;
  - Wind average recurrence interval of **50** years (ultimate), **25** years (serviceability);
  - Wind regions **NZ1, NZ2, NZ3, NZ4**;
  - Ms=1, Mt=1, Md=1, Mlee=1;
- Earthquake Loads to **NZS 1170.5:2004**;
- PV panels width up to **1400mm**, length (Lp) refer further pages, mass **15kg/m<sup>2</sup>**;
- Tilt angles considered **20** and **30** degrees. Other tilt angles are also possible but with other frame dimensions;
- Materials Strength calculated: steel post 400MPa (Q355B), aluminium members 240MPa (AL6005-T5).

## CONTENT

### Part 1.

SolarTerrace II-A (**Single** Support) installation in New Zealand (solar panels **up to 1800 mm** long) (**superseding** letter **6396-1**)

### Part 2.

SolarTerrace II-A (**Double** Support) installation in New Zealand (solar panels **up to 2000 mm** long) (**superseding** letter **6396-2**)

### Part 3.

SolarTerrace II-A (**Double** Support) installation in New Zealand (solar panels **2001 - 2400 mm** long) (**superseding** letter **7375-1**)

### Part 4.

SolarTerrace II-A (**Single** Support with **Extension**) installation in New Zealand (solar panels **up to 2000 mm** long) (**superseding** letter **7802-1**)

## Tables

### Table 1.

Maximum Frame Spacing (S) and Footing Options for Standard STII-A (Single Support) with solar panels up to 1800 mm long.

### Table 2.

Maximum Frame Spacing (S) and Footing Options for Standard STII-A (Double Support) with solar panels up to 2000 mm long.

### Table 3.

Factors (to multiply values S and D from table 2) for Installation of STII-A (Double Support, with extended girder = 200+3200+200mm) with solar panels 2001 - 2400 mm long.

Example of finding maximum spacing and footing option, using Table 3.

### Table 4.

Factors (to multiply values S and D from table 1) for Installation of STII-A (Single Support, with extended girder = 200+2800+200mm) with solar panels up to 2000 mm long.

### Table 5.

Explanation of the adopted soil classes.

## Pictures

Fig. 1. Example Cross Frame for table 1, tilt 20 degrees, driven post

Fig. 2. As Fig. 1, but post embedded in concrete pier

Fig. 3. As Fig. 1, but tilt 30 degrees

Fig. 4. As Fig. 2, but tilt 30 degrees

Fig. 5. Example Cross Frame for table 2, tilt 20 degrees, driven post

Fig. 6. As Fig. 5, but post embedded in concrete pier

Fig. 7. As Fig. 5, but tilt 30 degrees

Fig. 8. As Fig. 6, but tilt 30 degrees

Fig. 9. Example Cross Frame for table 4, tilt 20 degrees, driven post

Fig. 10. As Fig. 9, but tilt 30 degrees

## Appendices

A1. Explanation of Importance Levels

A2. Map of Wind Regions in New Zealand

## Part 1. SolarTerrace II-A (Single Support) installation in New Zealand (solar panels up to 1800 mm long)

**Table 1.** Maximum Frame Spacing (S) and Footing Options for Standard STII-A (Single Support) with solar panels up to 1800 mm long.

Wind Region	NZ1 & NZ2		NZ3 & NZ4	
Panels tilt angle, degrees	<b>20</b>	<b>30</b>	<b>20</b>	<b>30</b>
Wind speed, m/s	41		48 & 46	
Panel clearance (Cp), mm, max/min	532 / 395	600 / 426	532 / 395	600 / 426
Max/Min post height above the ground, mm, from Clenergy	1000 / 863	1399 / 1300	1000 / 863	1399 / 1300
Spacing (S), m	<b>3.50</b>	<b>3.30</b>	<b>3.40</b>	<b>2.70</b>
Max Vertical Uplift Reaction, kN	10.4	14.3	14.5	16.6
Max Vertical Down Reaction, kN	11.3	14.1	14.3	15.1
Max Horizontal Reaction, kN	4.4	9.3	5.9	10.4
Max Moment at GL, kNm	10.1	17.9	13.4	20.0
<b>Soil Class</b>	<b>Driven post minimum depth (D), m</b>			
Compact sand	1.45	N/A	1.63	N/A
Medium dense sand	1.90	N/A	N/A	N/A
Very Stiff to Hard clays	1.50	N/A	1.69	N/A
Firm to Stiff Clays	N/A	N/A	N/A	N/A
<b>Driven post maximum depth: based on standard 2800 mm long post (m), from Clenergy</b>	<b>1.937</b>	<b>1.500</b>	<b>1.937</b>	<b>1.500</b>
<b>Soil Class</b>	<b>Post embedded in concrete pier: 300 mm diameter concrete piers minimum depth (D), m</b>			
Compact sand	0.95	1.20	1.05	1.25
Medium dense sand	1.20	1.50	1.35	1.60
Very Stiff to Hard clays	0.95	1.20	1.05	1.25
Firm to Stiff Clays	1.30	1.75	1.50	1.85

### Notes:

1.1. This certification is applicable for Standard STII-A (single support) with dimensions as shown in the Figures 1-4 and the panel clearance above the ground (Cp) as mentioned in the Table 1. Contact Gamcorp for customised STII-A or if the site conditions are not covered by the soil classes considered in this assessment;

1.2. The length of the T-Rails overhang shall be up to 0.4x installed spacing;

1.3. For **25** degrees tilt angle the spacing and footing options can be interpolated between 20° and 30°. Cp = 411-589 mm, post height = 1200-1085 mm AG, post depth 1715 mm maximum;

1.4. For concrete piers foundation we recommend using 25 MPa strength plain concrete;

1.5. The post shall be embedded in the pier for approximately 0.6-0.9 of the pier depth;

1.6. Other pier sizes are possible. In case of ø250mm concrete pier, the pier depth will increase approx. 20% compared to the ø300mm pier. Contact Gamcorp for the pier depths of other pier diameters.

## Part 2. SolarTerrace II-A (Double Support) installation in New Zealand (solar panels 1801 - 2000 mm long)

**Table 2.** Maximum Frame Spacing (S) and Footing Options for Standard STII-A (Double Support) with solar panels up to 2000 mm long.

Wind Region	NZ1 & NZ2		NZ3 & NZ4	
Panels tilt angle, degrees	<b>20</b>	<b>30</b>	<b>20</b>	<b>30</b>
Wind speed, m/s	41		48 & 46	
Panel clearance (Cp), mm, max/min	691 / 554	560 / 445	691 / 554	560 / 445
Max/Min post height above the ground, mm, from Clenergy	1000 / 863	1200 / 1085	1000 / 863	1200 / 1085
Spacing (S), m	<b>3.30</b>	<b>2.80</b>	<b>3.20</b>	<b>2.10 (2.00*)</b>
Max Vertical Uplift Reaction, kN	11.1	13.7	15.3	14.5
Max Vertical Down Reaction, kN	11.6	13.1	14.7	12.9
Max Horizontal Reaction, kN	4.6	8.8	6.2	9.0
Max Moment at GL, kNm	12.1	19.4	16.0	19.9
<b>Soil Class</b>	<b>Driven post minimum depth (D), m</b>			
Compact sand	1.55	N/A	1.75	N/A
Medium dense sand	N/A	N/A	N/A	N/A
Very Stiff to Hard clays	1.60	N/A	1.85	N/A
Firm to Stiff Clays	N/A	N/A	N/A	N/A
<i>Driven post maximum depth: based on standard 2800 mm long post (m), from Clenergy</i>	<i>1.937</i>	<i>1.715</i>	<i>1.937</i>	<i>1.715</i>
<b>Soil Class</b>	<b>Post embedded in concrete pier: 300 mm diameter concrete piers minimum depth (D), m</b>			
Compact sand	1.00	1.20	1.10	1.20
Medium dense sand	1.25	1.55	1.40	1.55
Very Stiff to Hard clays	1.00	1.25	1.15	1.25
Firm to Stiff Clays	1.40	1.75	1.60	1.80

### Notes.

2.1. This certification is applicable for Standard STII-A (double support) with dimensions as shown in the Figures 5-8 and the panel clearance above the ground (Cp) as mentioned in the Table 2. Contact Gamcorp for customised STII-A or if the site conditions are not covered by the soil classes considered in this assessment;

2.2. Refer Note 1.2;

2.3. (\*) in the table applicable for the cases when using Clenergy East-West adaptor (if different to the spacing without adaptor);

2.4. Refer Note 1.4;

2.5. Refer Note 1.5;

2.6. Refer Note 1.6.

### Part 3. SolarTerrace II-A (Double Support) installation in New Zealand (solar panels 2001 - 2400 mm long)

**Table 3.** Factors (to multiply values S and D from table 2) for Installation of STII-A (Double Support, with extended girder = 200+3200+200mm) with solar panels 2001 - 2400 mm long.

panel dimensions 1400mm x (mm)			wind NZ1 & NZ2, 20 degree	wind NZ1 & NZ2, 30 degree	wind NZ3 & NZ4, 20 degree	wind NZ3 & NZ4, 30 degree
Reduction factor for frame spacing	2001-2100		1.00	0.93	1.00	0.90
	2101-2200		0.97	0.86	0.97	0.81
	2201-2300		0.94	0.79	0.92	0.71
	2301-2400		0.91	0.71	0.88	0.62
Increasing factor for minimum post ramming depth*	2001-2100	Compact sand	1.04	N/A	1.03	N/A
	2101-2200		1.06	N/A	1.05	N/A
	2201-2300		1.08	N/A	1.06	N/A
	2301-2400		1.10	N/A	1.07	N/A
Increasing factor for minimum concrete pier depth*	2001-2100	Compact sand	1.00	1.00	1.09	1.00
		Medium dense sand	1.12	1.03	1.07	1.03
		Very Stiff to Hard clays	1.10	0.96	1.04	0.96
		Firm to Stiff Clays	1.14	1.03	1.06	0.94
	2101-2200	Compact sand	1.00	1.00	1.09	1.00
		Medium dense sand	1.12	1.03	1.07	1.03
		Very Stiff to Hard clays	1.10	0.96	1.04	0.96
		Firm to Stiff Clays	1.14	1.03	1.06	0.94
	2201-2300	Compact sand	1.00	1.00	1.09	1.00
		Medium dense sand	1.12	1.03	1.07	1.03
		Very Stiff to Hard clays	1.10	0.96	1.04	0.96
		Firm to Stiff Clays	1.14	1.03	1.06	0.94
	2301-2400	Compact sand	1.00	1.00	1.09	1.00
		Medium dense sand	1.12	1.03	1.07	1.03
		Very Stiff to Hard clays	1.10	0.96	1.04	0.96
		Firm to Stiff Clays	1.14	1.03	1.06	0.94

Note(\*): In some cases the pier depth is decreased as a result of the smaller spacing.

Example see next page.

**Example of finding maximum spacing and footing option, using Table 3.**

Case:

Wind Region	Region NZ1
Panel length,mm	2300
Tilt, degrees	20
Soil	Compact sand

Find in Table 2:

Spacing, m	3.30
Driven post depth, m	1.55
Pier ø300 depth, m	1.00

Find in Table 3:

panel dimensions 1400mm x (mm)			wind A 20 degree	From Table 2	Result for 2300mm panel
Reduction factor for frame spacing	2001-2100		1.00		
	2101-2200		0.97		
	<b>2201-2300</b>		<b>0.94</b>	<b>3.30</b>	<b>3.10</b>
	2301-2400		0.91		
Increasing factor for minimum <b>post ramming</b> depth	2001-2100	<b>Compact sand</b>	1.04		
	2101-2200		1.06		
	<b>2201-2300</b>		<b>1.08</b>	<b>1.55</b>	<b>1.67</b>
	2301-2400		1.10		
Increasing factor for minimum <b>concrete pier</b> depth	2001-2100	Compact sand	1.00		
		Medium dense sand	1.12		
		Very Stiff to Hard clays	1.10		
		Firm to Stiff Clays	1.14		
	2101-2200	Compact sand	1.00		
		Medium dense sand	1.12		
		Very Stiff to Hard clays	1.10		
		Firm to Stiff Clays	1.14		
	<b>2201-2300</b>	<b>Compact sand</b>	<b>1.00</b>	<b>1.00</b>	<b>1.00</b>
		Medium dense sand	1.12		
		Very Stiff to Hard clays	1.10		
		Firm to Stiff Clays	1.14		
	2301-2400	Compact sand	1.00		
		Medium dense sand	1.12		
		Very Stiff to Hard clays	1.10		
		Firm to Stiff Clays	1.14		

**Part 4. SolarTerrace II-A (Single Support with Extension) installation in New Zealand (solar panels up to 2000 mm long)**

**Table 4.** Factors (to multiply values S and D from table 1) for Installation of STII-A (Single Support, with extended girder = 200+2800+200mm) with solar panels up to 2000 mm long.

panel dimensions 2000x1400		wind NZ1 & NZ2, 20 degree	wind NZ1 & NZ2, 30 degree	wind NZ3 & NZ4, 20 degree	wind NZ3 & NZ4, 30 degree
Reduction factor for frame spacing		0.71	0.55	0.74	0.59
Increasing factor for minimum post ramming depth*	Compact sand	0.92	N/A	0.93	N/A
	Compact sand	0.95	0.83	0.95	0.88
Increasing factor for minimum concrete pier depth*	Medium dense sand	0.92	0.87	0.96	0.88
	Very Stiff to Hard clays	0.95	0.83	0.95	0.88
	Firm to Stiff Clays	0.92	0.86	0.93	0.86

*Note(\*): In some cases the footing depth is decreased as result of the required smaller spacing. Other pier sizes are possible. In the case of ø250mm concrete pier, the pier depth will increase approx. 20% comparing with the ø300mm pier. Contact Gamcorp for the pier depths of other pier diameters.*

**Table 5.** Explanation of the adopted soil classes

	ABC (Allowable Bearing Capacity), kPa
Compact sand	≥ 300
Medium dense sand	150 - 300
Very Stiff to Hard clays	300 - 600
Firm to Stiff Clays	100 - 150

The maximum frame spacing is based on the structural capacity of the frame in the perimeter zone of an array. We recommend performing tests on site for the geotechnical capacity of the driven post. The spacing may need to be decreased to achieve the available geotechnical capacity of the driven post following from the test results.

Construction is to be carried out strictly in accordance with the instruction manual. This work was designed in accordance with the provisions of New Zealand’s Building Regulations and in accordance with sound, widely accepted engineering principles. This certification **excludes** assessment of the members durability/corrosion and PV panels. This certification is valid till **May 31, 2025**, unless any of the relevant Standards/regulations become updated before the due date.

Yours faithfully,  
Gamcorp Pty Ltd



**L. Van Spaandonk**  
Principal Engineer  
FIEAust CPEng NER APEC Engineer IntPE(Aus) CEngNZ 2003796

Frames pictures (examples):

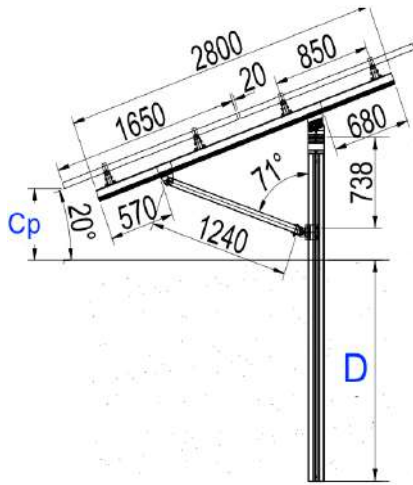

Fig. 1

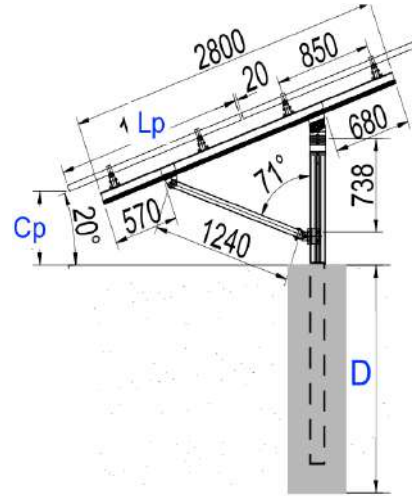

Fig. 2

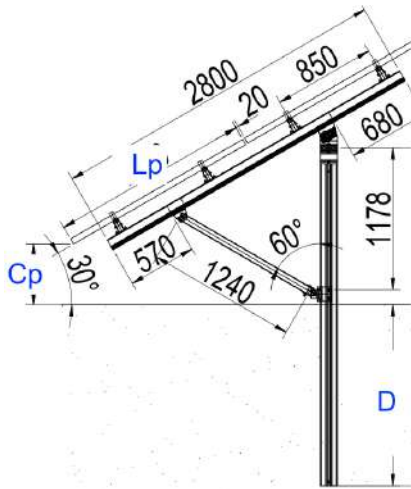

Fig. 3

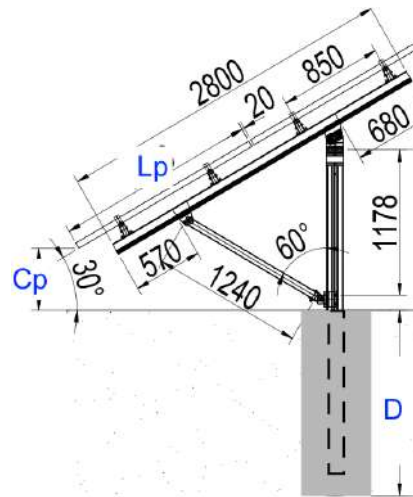

Fig. 4

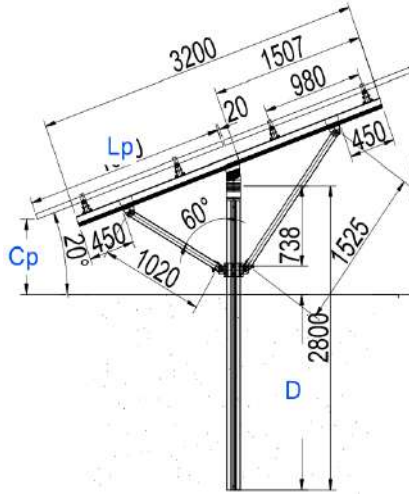

Fig. 5

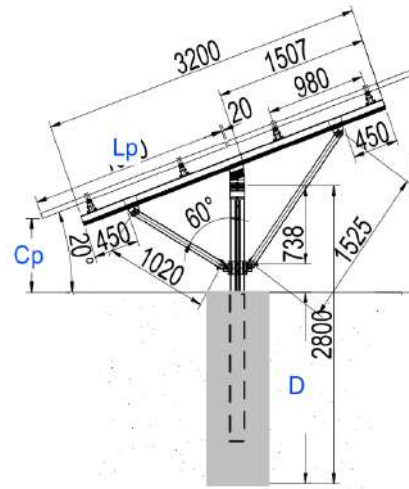

Fig. 6

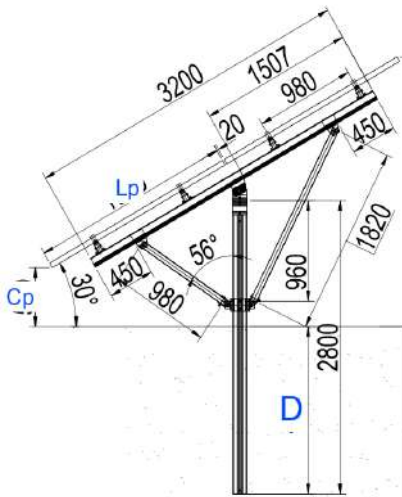

Fig. 7

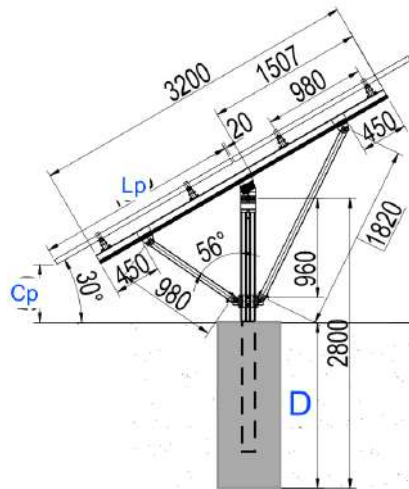

Fig. 8

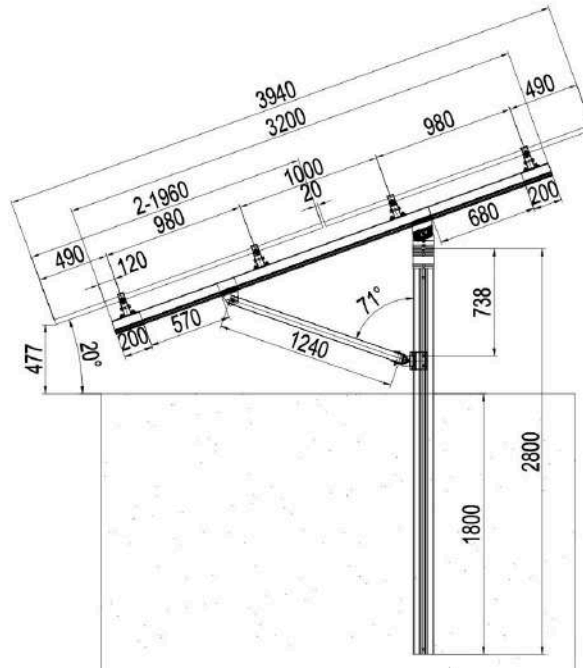

Fig. 9

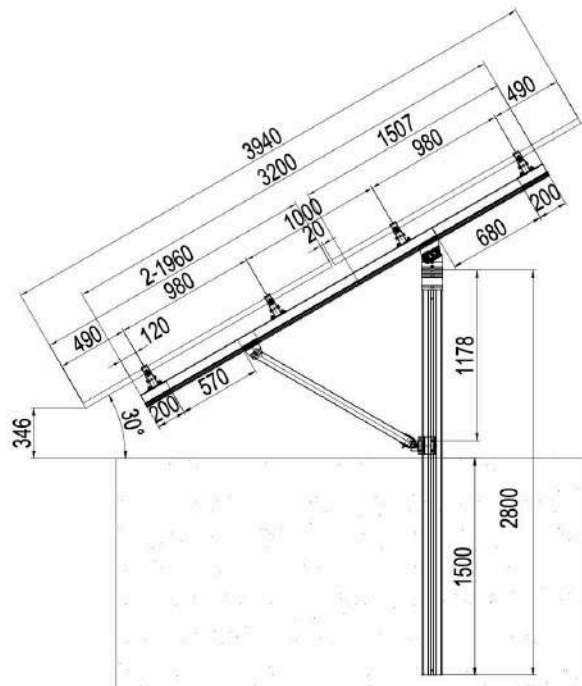

Fig. 10

## Appendices

### **A1. Explanation of Importance Level**

(Tables 3.1, 3.3 from AS/NZS-1170\_0-2002 - Structural design actions - General principles - amendments 1-5 incorporated)

**TABLE 3.1**

#### **CONSEQUENCES OF FAILURE FOR IMPORTANCE LEVELS**

Consequences of failure	Description	Importance level	Comment
Low	<b>Low</b> consequence for loss of human life, <i>or</i> <b>small or moderate</b> economic, social or environmental consequences	1	Minor structures (failure not likely to endanger human life)
Ordinary	<b>Medium</b> consequence for loss of human life, <i>or</i> <b>considerable</b> economic, social or environmental consequences	2	Normal structures and structures not falling into other levels
High	<b>High</b> consequence for loss of human life, <i>or</i> <b>very great</b> economic, social or environmental consequences	3	Major structures (affecting crowds)
		4	Post-disaster structures (post disaster functions or dangerous activities)
Exceptional	Circumstances where reliability must be set on a case by case basis	5	Exceptional structures

New Zealand only

**TABLE 3.3**

12b

#### **ANNUAL PROBABILITY OF EXCEEDANCE**

Design working life	Importance level	Annual probability of exceedance for ultimate limit states			Annual probability of exceedance for serviceability limit states	
		Wind	Snow	Earthquake	SLS1	SLS2 Importance level 4 only
Construction equipment, e.g., props, scaffolding, braces and similar	2	1/100	1/50	1/100	1/25	
Less than 6 months	1	1/25	1/25	1/25	—	
	2	1/100	1/50	1/100	1/25	
	3	1/250	1/100	1/250	1/25	
	4	1/1000	1/250	1/1000	1/25	
5 years	1	1/25	1/25	1/25	—	—
	2	1/250	1/50	1/250	1/25	—
	3	1/500	1/100	1/500	1/25	—
	4	1/1000	1/250	1/1000	1/25	1/250
25 years	1	1/50	1/25	1/50	—	—
	2	1/250	1/50	1/250	1/25	—
	3	1/500	1/100	1/500	1/25	—
	4	1/1000	1/250	1/1000	1/25	1/250
50 years	1	1/100	1/50	1/100	—	—
	2	1/500	1/150	1/500	1/25	—
	3	1/1000	1/250	1/1000	1/25	—
	4	1/2500	1/500	1/2500	1/25	1/500
100 years or more	1	1/250	1/150	1/250	—	—
	2	1/1000	1/250	1/1000	1/25	—
	3	1/2500	1/500	1/2500	1/25	—
	4	*	*	*	1/25	*

## A1. Explanation of Importance Level (continued)

(Table 3.2 from AS/NZS-1170\_0-2002 - Structural design actions - General principles - amendments 1-5 incorporated)

**TABLE 3.2**

### IMPORTANCE LEVELS FOR BUILDING TYPES—NEW ZEALAND STRUCTURES

Importance level	Comment	Examples
1	Structures presenting a low degree of hazard to life and other property	Structures with a total floor area of <math><30\text{ m}^2</math> Farm buildings, isolated structures, towers in rural situations Fences, masts, walls, in-ground swimming pools
2	Normal structures and structures not in other importance levels	Buildings not included in Importance Levels 1, 3 or 4 Single family dwellings Car parking buildings
3	Structures that as a whole may contain people in crowds or contents of high value to the community or pose risks to people in crowds	Buildings and facilities as follows: (a) Where more than 300 people can congregate in one area (b) Day care facilities with a capacity greater than 150 (c) Primary school or secondary school facilities with a capacity greater than 250 (d) Colleges or adult education facilities with a capacity greater than 500 (e) Health care facilities with a capacity of 50 or more resident patients but not having surgery or emergency treatment facilities (f) Airport terminals, principal railway stations with a capacity greater than 250 (g) Correctional institutions (h) Multi-occupancy residential, commercial (including shops), industrial, office and retailing buildings designed to accommodate more than 5000 people and with a gross area greater than 10 000 m <sup>2</sup> (i) Public assembly buildings, theatres and cinemas of greater than 1000 m <sup>2</sup>  Emergency medical and other emergency facilities not designated as post-disaster  Power-generating facilities, water treatment and waste water treatment facilities and other public utilities not designated as post-disaster  Buildings and facilities not designated as post-disaster containing hazardous materials capable of causing hazardous conditions that do not extend beyond the property boundaries
4	Structures with special post-disaster functions	Buildings and facilities designated as essential facilities Buildings and facilities with special post-disaster function Medical emergency or surgical facilities Emergency service facilities such as fire, police stations and emergency vehicle garages Utilities or emergency supplies or installations required as backup for buildings and facilities of Importance Level 4 Designated emergency shelters, designated emergency centres and ancillary facilities Buildings and facilities containing hazardous materials capable of causing hazardous conditions that extend beyond the property boundaries
5	Special structures (outside the scope of this Standard—acceptable probability of failure to be determined by special study)	Structures that have special functions or whose failure poses catastrophic risk to a large area (e.g. 100 km <sup>2</sup> ) or a large number of people (e.g., 100 000) Major dams, extreme hazard facilities

**A2. Map of Wind Regions in New Zealand**

(from AS/NZS-1170\_2-2021 - Structural design actions - Part 2: Wind actions)

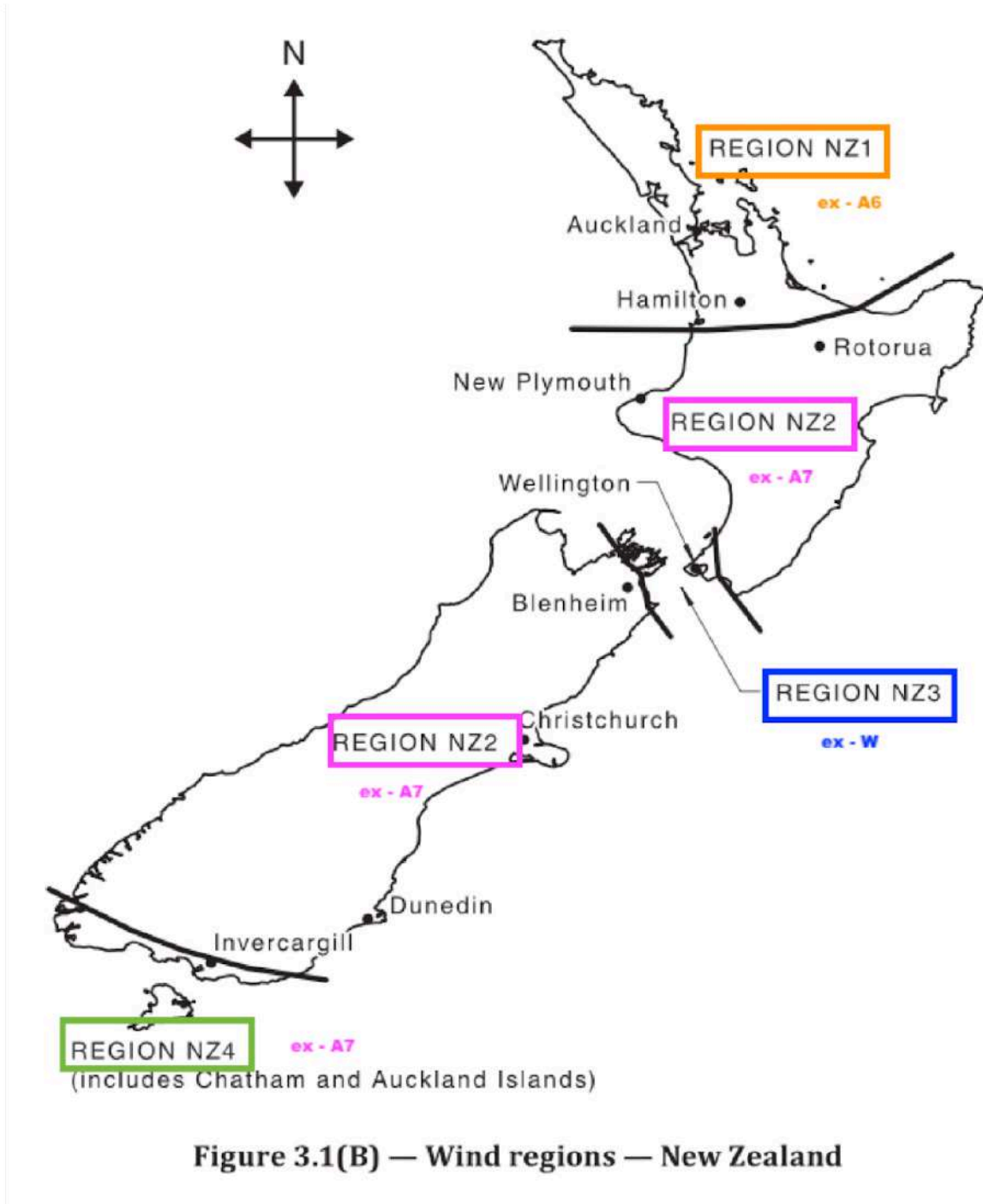





## PV-ezRACK®

### Clenergy

1/10 Duerdin St  
Clayton VIC 2168  
Australia

Phone: +61 3 9239 8088  
Email: [sales@clenergy.com.au](mailto:sales@clenergy.com.au)  
Web: [www.clenergy.com.au](http://www.clenergy.com.au)

 @ClenergyGlobal / @ClenergyClub / ClenergyAUS  @Clenergy  @ClenergyClub  
 @Clenergy\_global  @Clenergy

A Clenergy Technologies Company